



俊和 - 中國中鐵聯營

CHUN WO - CRGL JOINT VENTURE

Contract No. HK/2009/02

Wan Chai Development Phase II

Central - Wan Chai Bypass at Wan Chai East

Silt Screen Deployment Plan

---

## Silt Screen Deployment Plan

A	12/04/10	Submission for Approval	Cecil Cheng <i>ccy</i>	P C Chan <i>pc</i>
0	11/03/10	Submission for Approval	Cecil Cheng	P C Chan
Rev	Date	Status	Prepared By	Reviewed and Approved By Construction Manager



<b>LIST OF CONTENTS</b>	<b>Page</b>
<b>1.0 Introduction</b>	<b>3</b>
<b>2.0 List of documentation to be referenced</b>	<b>3</b>
<b>3.0 General Layout of Location of Silt Screen</b>	<b>3</b>
<b>4.0 Deployment Schedule</b>	<b>4</b>
<b>5.0 Installation Method</b>	<b>4</b>
<b>6.0 Maintenance and Removal</b>	<b>5</b>
<b>7.0 Technical Details and Materials for the Silt Screen</b>	<b>6</b>
<b>8.0 Appendices</b>	<b>6</b>



俊和 - 中國中鐵聯營

CHUN WO - CRGL JOINT VENTURE

Contract No. HK/2009/02

Wan Chai Development Phase II

Central - Wan Chai Bypass at Wan Chai East

Silt Screen Deployment Plan

## 1.0 Introduction

The purpose of this deployment plan is to illustrate the general layout, the construction programme, details on the design, operation and maintenance of the silt screens to be installed for the dredging and filling works of "Wan Chai Reclamation" as recommended in the approved EIA report (Registration No.: AEIAR-125/2008).

## 2.0 List of documentation to be referenced

2.1 Particular Specification, the relevant clauses and our remarks for the works are listed as follows for ease of references.

PS Clause No.	Relevant Remarks
PS Appendix 25.4, EP No. EP-356/2009 Clause 2.9 refers.	The permit holder shall liaise with the owners and the operators of the seawater intakes on details of silt screen installation, maintenance and removal at the seawater intakes.
PS Appendix 25.4, EP No. EP-356/2009 Clause 2.9 refers.	At least two weeks prior to the commencement of the marine works, the permit holder shall deposit with the Director four hard copies and one electronic copy of a silt screen deployment plan to provide details of the design, operation and maintenance requirement of the silt screen systems.
PS Appendix 25.4, EP No. EP-356/2009 Clause 2.9 refers.	The silt screen deployment plan shall be certified by the ET Leader and verified by the IEC as conforming to the relevant information and recommendation contained in the approved EIA report (Reg. No. AEIAR-125/2008) and liaison results with the owners and the operators of the seawater intakes.
PS Appendix 25.4, EP No. EP-356/2009 Clause 2.9 refers.	Silt screens shall be installed at seawater intakes prior to the commencement of the corresponding marine works.
PS Appendix 25.4, EP No. EP-356/2009 Clause 2.9 refers.	To avoid refuse entrapment and to ensure representative impact monitoring results, silt screens shall be maintained and refuse around them shall be collected at regular intervals on a daily basis so that water behind the silt screens be kept free from floating debris during the impact monitoring period.

## 3.0 General Layout of Location of Silt Screen

3.1 The deployment of Silt Screen would be divided into two phase as follow:

3.1.1 **Phase 1 Silt Screens** to be deployed prior to the reclamation works of WCR1. The silt screen to be installed at the existing **WSD salt water intakes** and existing **Sun Hung Kai Centre intakes**. It is anticipated to be installed by **mid of April 2010** and would be maintained for approximate **24 months** until the



commissioning of the new WSD salt water pumping station and new Sun Hung Kai Centre pumping station by early March 2012.

3.1.2 **Phase 2 Silt Screens** to be deployed prior to the reclamation works of WCR2. The silt screen to be installed at the intakes of proposed **WSD salt water pumping station**, proposed **Sun Hung Kai pumping station**, proposed **China Resource Building pumping station** and proposed **Great Eagle Centre/ harbour Centre**. It is anticipated to be installed by **mid of February 2012** and would be maintained for approximately **43 months** until the anticipated completion of all marine works by mid August 2015.

3.2 The layout plans and schedule for deployment of silt screens at different phases mentioned should refer to Appendix A.

#### 4.0 Deployment Schedule

4.1 The deployment schedule of the silt screens could refer to the table below. It is prepared based on the Initial Works Programme and may subject to changes to reflect the actual site progress:

Staging	Anticipated Installation Works		Silt Curtain to be Maintained until	Anticipated Removal by	Total Duration, days = (b) - (a)
	From (a)	To			
Phase 1	15 April, 2010	30 April, 2010	15 March, 2012	15 March, 2012	700
Phase 2	1 February, 2012	15 February, 2012	4 August, 2015	4 August, 2015	1280

4.2 Silt screens installations would be completed prior to the commencement of relevant phase of dredging works, the silt screens would only be removed upon completion of the relevant phases or as agreed with the Engineer.

#### 5.0 Installation Method

##### 5.1 Preparation

5.1.1 Prior to installation of the silt screen, the contractor would liaise with relevant operators for the operation. The pump stations each consist of 2 to 4 number of water intake pipes. Temporary suspension of pump of each intake pipe in turns is required prior to the installation of the respective silt screen system to each intake pipe. The silt screen to each water intake pipe would be installed one by one such that the overall operations of the pump house would not be adversely affected. The schedule of installation works should be agreed by the relevant stakeholders.



- 5.1.2 The silt screen system would consist of a frame mounted on the external wall of the intake, and a steel fence with geotextile to be inserted into the frame. The silt screen system would be pre-fabricated prior to the installations. Extra number of steel fences with geotextile would be fabricated as standby unit in case of any repairing works required in the future. The details of the pre-fabrication units should refer to Appendix B.
- 5.2 Installation of the wall mounted frame
- 5.2.1 The relevant pump of water intake pipe should be switched off. The pre-fabricated steel frame would be lifted to the required position by use of mobile crane.
- 5.2.2 A foreman would be sited at location near the shoreline to supervise the operation.
- 5.2.3 Divers would be located at sea near the shoreline to help placing the steel frame in position and for installation of the frame to the external wall of the water pump house by bolt and nuts anchorage.
- 5.2.4 Holes drilling to the external wall would be carried out by the divers using pneumatic air driller and Hilti bolt Type HSL-3 or equivalent would be adopted as the anchorage system.
- 5.2.5 Refer to Appendix C for the graphical illustration of the installation of the wall mounted steel frame.
- 5.3 Installation of the silt screen fencing into the wall mounted frame
- 5.3.1 The relevant silt screen fencing should be inserted into the wall mounted frame. A foreman would be sited at location near the shoreline to supervise the operation.
- 5.3.2 The pump of water intake pipe should be switched off. The pre-fabricated silt screen fencing would be lifted to the required position by use of mobile crane.
- 5.3.3 Divers would be located at sea near the shoreline to help placing of the silt screen fencing to proper positions. A steel wire would be installed to the lifting eye of the silt screen fencing for ease of later maintenance. The steel wire would then be brought up to the ground level and fix to the chain block pulley would to be installed on land.
- 5.3.4 Refer to Appendix C for the graphic illustration of the installation of the silt screen fencing into the wall mounted frame.
- 5.4 Silt Screen has been designed to have sufficient clearance from the external wall of the pump houses to allow placing of relevant equipment by Environmental Team to carry out water measurement and sampling behind the screens. Either marine access or land



access would be maintained at all time for the Environmental Team to perform their monitoring duties, layout plans illustrating the access routes are attached in Appendix G.

## 6.0 Maintenance and Removal

- 6.1 Site foreman and supervisors will be assigned to check the condition of the silt screens at regular intervals on a daily basis during the course of the marine works. An inspection checklist with format as attached in Appendix D would be used for recording the conditions of the silt screens.
- 6.2 Completed checklists will be kept on site for record.
- 6.3 If silt screens are found damaged and repairing works are identified as necessary, all marine works at our works area in relation to the location of silt screens would be suspended. The silt screens would be lifted up from the sea by using chain block pulley system, and the damaged parts (e.g. geotextile filter, steel mesh, steel frame...etc) of silt screens would be replaced.
- 6.4 The suspended marine works as mentioned could only be resumed after satisfactorily repairing of the damaged silt screens.
- 6.5 As regular maintenance, refuse around the silt screens would be collected on daily basis to avoid blockage of sea water flow by floating debris.
- 6.6 Spare geotextile materials and pre-fabricated silt screen would be stored on site. It would be treated as standby materials to allow for prompt replacement in case of any damages the silt screens observed.
- 6.7 Prior to removal of the silt screen, relevant intake of water pump stations should be temporarily switched off. The contractor would liaise with relevant operators for the operation. The silt screen would then be lifted up by using chain block pulley system. Any screw nuts of anchor bolts to be loosen under the water level would be carried out by using divers.

## 7.0 Technical Details and Materials for the Silt Screen

- 7.1 The Silt Screens would be pre-fabricated on site prior to installation to the relevant intakes. The typical details and calculation checking of the silt screen system should refer to Appendix B. ICE checking certificates would be separately submitted to the Engineer on site.
- 7.2 The permeable Silt Screens would consist of geotextile materials. The technical properties of the geotextile materials should refer to Appendix E.
- 7.3 The Silt Screen would also consist of steel mesh material as fencing. The technical properties of the steel mesh material should refer to Appendix F. Galvanized mild steel mesh will be used.



- 7.4 All other steel materials for the steel frame to be complied with Grade 43A or S275 standards. All steel materials to be galvanized mild steel.

## 8.0 Liaison Results with the Intake Owner and Operator

### 8.1 Silt Screens for Existing Sun Hung Kei Pump Station Intakes

8.1.1 Responsible person named Mr. Y. C. Lee, posted Senior Maintenance Engineer, tel: 3766 6164, mobile 9160 6832 and e-mail: ycleel1@shkmgmt.com.

8.1.2 It is agreed that the silt screens to be mounted on the external wall face of the pump house. The permeable silt screens should be removable type and the screens should be lifted up and removed upon requested from Sun Hung Kei Pump Station for ease of their regular maintenance.

8.1.3 It is principally agreed that the installations of silt screens to be carried out on Saturday. The exact schedule of installation work shall be further coordinated in order to minimize downtime of the sea water pumps.

8.1.4 Trial test shall be performed on site to check the functionality of the silt screens before it is put into full operations.

### 8.2 Silt Screens for Existing WSD Pump Station Intakes

8.2.1 Responsible person named Mr. K. Y. Hong, posted Inspector Mechanical, tel: 2880 2528 and e-mail: kam\_yiu\_hong@wsd.gov.hk.

8.2.2 It is agreed that the silt screens to be mounted on the external wall face of the pump house. The permeable silt screens should be removable type and the screens should be lifted up and removed upon requested from Water Supplies Department for ease of their regular maintenance.

8.2.3 It is agreed that the base and sides of the wall mounted frame to be sealed up by fixed steel plate instead of hanging curtain materials, to ensure protection to the intake systems.

8.2.4 The exact date for installation works should be further confirmed with WSD representative prior to operations.

### 8.3 Silt Screens for other Proposed Pump Station Intakes

8.3.1 Liaisons with relevant owners to be carried out at least one month prior to installations of relevant silt screens.



8.3.2 The design and installation details of the silt screens for the proposed pump houses to be discussed and agreed with relevant owners prior to functioning of relevant pump houses on 2012.

## 9.0 Appendices

- 9.1 Appendix A - Silt Screen Deployment Plan
- 9.2 Appendix B - Detailed Drawing and Calculation Checking of the Silt Screen System
- 9.3 Appendix C - Graphical Illustration for the Installations of the Silt Screen System
- 9.4 Appendix D - Daily Inspection Checklist
- 9.5 Appendix E - Technical Properties of the Geotextile Material - Tencate Mirafi FW300
- 9.6 Appendix F - Technical Properties of the Steel Mesh Material - Golik 228G
- 9.7 Appendix G - Access of Environmental Team to carry out water measurement and sampling



**9.1 Appendix A**  
**– Silt Screen Deployment Plan**

ACTIVITY	DURATION	START	FINISH
<b>PHASE 1 SILT SCREEN</b> Installation of silt screen at existing intakes of WSD salt water pump houses & SHK Centre pump station prior to WCR reclamation & to be maintained until commission of phase 2 silt screen	Approx. 24 months	30/04/10	15/03/12
<b>PHASE 2 SILT SCREEN</b> Installation of silt screen at proposed intakes of pump stations of Great Eagle Centre Harbour Centre, SHK Centre, China Resource Building, and WSD Salt Water Pump House prior to commissioning of the new pump stations & to be maintained until completion of marine works	Approx. 43 months	15/02/12	04/08/15

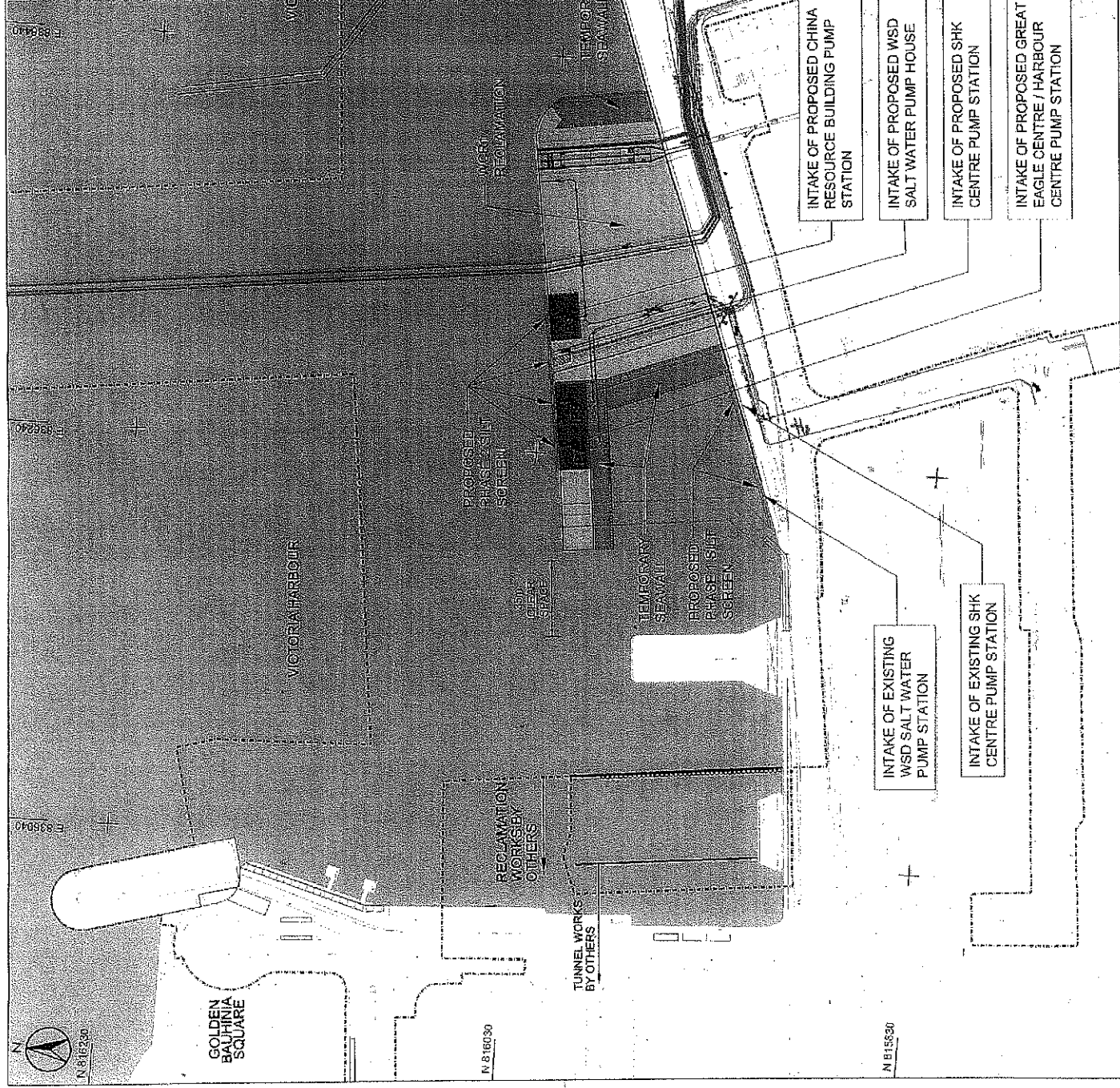

1:2000  
 1:2000 SCALE BAR  
 0 20 40 60 METRES  
 © COPYRIGHT RESERVED  
 2010

土木工務發展部  
 Civil Engineering and  
 Development Department  
 香港中環中環中環  
 CHINA'S NEW-CENTRAL JIAOYU CENTER  
 WANG CHAU DEVELOPMENT PHASE  
 CENTRAL - WANG CHAU BYPASS AT WANG CHAU EAST

SILT SCREEN DEPLOYMENT PLAN  
 AECOM  
 PROJECT NO. HK/2009/02/MFR/007B  
 DRAWING NO. S-11-00000  
 DATE: 15/03/2010  
 SCALE: 1:2000

**9.2 Appendix B**  
**– Detailed Drawing and**  
**Calculation Checking of the Silt**  
**Screen System**

## Design Calculation

### Dimensions of steel fence:

Height of steel fence	=	3.050 m
width of steel fence	=	2.250 m
steel fence member	=	50 x 50 x 4mm Equal Angle
no. of steel fence for each frame	=	2.000 nr
weight of steel angle member	=	3.060 kg/m
weight of steel mesh member	=	3.960 kg/m <sup>2</sup>
weight of geotextile	=	0.275 kg/m <sup>2</sup>

### Loading of steel fences:

weight of steel member of each fence	=	32.436 kg
weight of 2 layer of steel mesh for each fence	=	54.351 kg
weight of 1 layer of geotextile for each fence	=	1.887 kg
Therefore, weight of each fence	=	88.674 kg
Factored DL = 1.2 x 10 x	88.674 =	1.064 kN
For 2.000 nr of fence,		
total factored DL	=	2.128 kN

### Dimensions of wall-mounted steel frame:

Height of steel frame	=	6.000 m
width of steel frame	=	2.300 m
steel frame member	=	102 x 51 x 10.6 kg/m
no. of steel frame for each silt screen	=	1.000 nr
weight of steel angle member	=	10.600 kg/m

### Loading of wall-mounted frame:

weight of major steel member of the frame	=	175.960 kg
weight of steel members for the MS plates	=	54.263 kg
Therefore, weight of each frame	=	230.223 kg
Factored DL = 1.2 x 10 x	230.223 =	2.763 kN

All steel material use to be Grade S275

**Capacity Check for the Steel Frame:**

**Check Bending to the bottom member of frame**

$$\begin{aligned} \text{design UDL} &= 2.128 \text{ kN} \\ \text{max. bending moment} &= 0.125 \times \text{UDL} \times L^2 \\ &= 1.347 \text{ kNm} \end{aligned}$$

$$\begin{aligned} \text{Use } 102 \times 51 \times 10.6 \text{ kg/m} \\ Z &= 8140.000 \text{ mm}^3 \\ \text{max. bending stress} &= 165.447 \text{ N/mm}^2 \\ &< 275.000 \text{ N/mm}^2 \end{aligned}$$

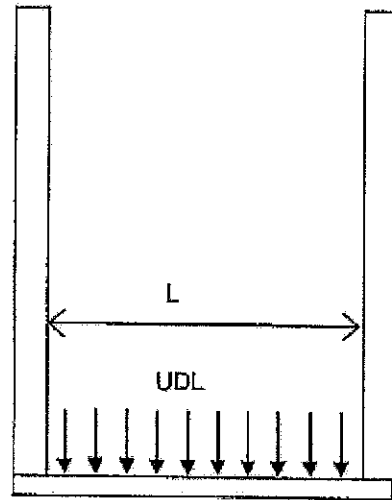

OK

**Check Shear at Support of the bottom steel frame**

$$\begin{aligned} \text{max. shear force, } V &= 2.394 \text{ kN} \\ \text{cross section area} &= 1330.000 \text{ mm}^2 \\ \text{max. shear stress} &= 1.800 \text{ N/mm}^2 \\ &< 165.000 \text{ N/mm}^2 \end{aligned}$$

OK

**Check Tension on the vertical members of the steel frame**

$$\begin{aligned} \text{max. shear force, } V &= 2.394 \text{ kN} \\ \text{total DL of the steel frame} &= 2.763 \text{ kN} \\ \text{DL at each vertical member} &= 1.381 \text{ kN} \\ \text{cross section area} &= 1330.000 \text{ mm}^2 \\ \text{max. tensile force} &= 3.776 \text{ kN} \\ \text{max. tensile stress} &= 2.839 \text{ N/mm}^2 \\ &< 275.000 \text{ N/mm}^2 \end{aligned}$$

OK

Apply 4mm fillet welds to all connctions unless otherwise stated

**Welding Check:**

$$\begin{aligned} \text{max. shear force} &= 2.394 \text{ kN} \\ \text{welding length required} &= \frac{2.394 \times 1000}{215.000 \times 4 \times 0.7} \\ &= 28.750 \text{ mm} \\ \text{Provide welding length} &= 50.000 \text{ mm} \quad \text{OK} \end{aligned}$$

**Capacity Check for the Cantilever Arm:**

Check Bending to the cantilever arm

$$\begin{aligned} \text{Cantilever arm} &= 0.800 \text{ m} \\ \text{Number of support at each side} &= 2.000 \text{ nr} \\ \text{max. bending moment} &= V \times \text{cantilever arm} / \text{nr of support} \\ &= 0.958 \text{ kNm} \\ \text{Use } 50 \times 50 \times 2.5\text{mm} &\times 3.68 \text{ kg/m} \\ Z &= 6990.000 \text{ mm}^3 \\ \text{max. bending stress} &= 137.007 \text{ N/mm}^2 \\ &< 275.000 \text{ N/mm}^2 \end{aligned}$$

Check Shear at the cantilever arm

$$\begin{aligned} \text{max. shear force, V} &= 2.394 \text{ kN} \\ \text{Number of support at each side} &= 2.000 \text{ nr} \\ \text{cross section area} &= 468.000 \text{ mm}^2 \\ \text{max. shear stress} &= 2.558 \text{ N/mm}^2 \\ &< 165.000 \text{ N/mm}^2 \end{aligned}$$

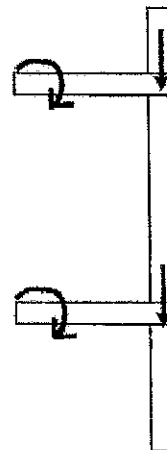

**Capacity Check for the Anchorage Bolts:**

Total factored DL of the steel frame and steel fence, W:

$$W = 4.891 \text{ kN}$$

Nos. of anchor bolts provided = 4.000 nr

max. shear force to each bolt = 1.223 kN

Use HSL-G-R M12 with 80mm anchorage length

max. allowable Shear Force at each bolt = 24.4 kN

$$> 1.223 \text{ kN} \quad \text{OK}$$

**Allowable Flow Capacity of the Silt Screen**

Flow capacity of the Geotextile FW300 = 90.000 L/m<sup>2</sup>/s

Total flow capacity allowable for each screen

$$= 2.25 \times 3.05 \times 2 \times 90$$

$$= 1235.25 \text{ L/s}$$

$$> \text{required flow rate} = 375 \text{ L/s}$$

OK

### f<sub>A</sub>: Influence of anchor spacing

Anchor spacing s [mm]	Tensile/Shear					
	M8	M10	M12	M16	M20	
85	0.70	0.70	0.70	0.70	0.70	
115	0.72	0.71	0.71	0.70	0.70	
145	0.73	0.71	0.71	0.70	0.70	
180	0.79	0.76	0.74	0.70	0.70	
230	0.85	0.81	0.79	0.73	0.70	
300	0.90	0.86	0.84	0.77	0.72	
400	0.95	0.90	0.87	0.80	0.75	
500	1.0	0.94	0.91	0.82	0.77	
600	1.0	1.0	0.97	0.87	0.80	
800	1.0	1.0	1.0	0.99	0.92	
1000	1.0	1.0	1.0	1.0	0.94	
1200	1.0	1.0	1.0	1.0	0.96	
1500	1.0	1.0	1.0	1.0	0.95	
2000	1.0	1.0	1.0	1.0	1.0	

$$f_A = 0.15 \frac{s}{h_{act}} + 0.55$$

$$S_{min} = h_{nom}, S_{sp} = 3 \cdot h_{act}$$

Separate multiple-anchor fastenings must be at least a  $\geq 2 \cdot S_{sp}$  apart to ensure they do not influence each other.

### f<sub>c</sub>: influence of edge distance

Edge distance c [mm]	Tensile f <sub>ct</sub>						Shear f <sub>ctd</sub>					
	M8	M10	M12	M16	M20	M20	M8	M10	M12	M16	M20	
85	0.70	0.70	0.70	0.70	0.70	0.70	0.30	0.30	0.30	0.30	0.30	
115	0.73	0.71	0.71	0.70	0.70	0.70	0.37	0.30	0.40	0.44	0.30	
145	0.75	0.71	0.71	0.70	0.70	0.70	0.40	0.44	0.48	0.58	0.44	
180	0.82	0.78	0.76	0.70	0.70	0.70	0.58	0.58	0.58	0.58	0.44	
230	0.80	0.85	0.83	0.74	0.70	0.70	0.77	0.74	0.74	0.59	0.41	
300	0.97	0.91	0.88	0.79	0.73	0.70	0.96	0.78	0.74	0.52	0.39	
400	1.0	0.93	0.90	0.80	0.75	0.70	1.0	0.85	0.78	0.55	0.41	
500	1.0	1.0	0.96	0.85	0.78	0.70	1.0	0.92	0.85	0.65	0.50	
600	1.0	1.0	1.0	0.88	0.80	0.70	1.0	1.0	0.72	0.55	0.55	
800	1.0	1.0	1.0	0.92	0.84	0.70	1.0	1.0	0.83	0.64	0.64	
1000	1.0	1.0	1.0	0.91	0.81	0.70	1.0	1.0	0.82	0.64	0.64	
1200	1.0	1.0	1.0	0.92	0.81	0.70	1.0	1.0	0.92	0.64	0.64	
1500	1.0	1.0	1.0	0.96	0.81	0.70	1.0	1.0	0.96	0.64	0.64	
2000	1.0	1.0	1.0	1.0	0.81	0.70	1.0	1.0	1.0	0.64	0.64	

$$f_{RN} = 0.2 \frac{c}{h_{act}} + 0.5$$

$$C_{min} = h_{nom}, C_{sp} = 2.5 \cdot h_{act}$$

$$f_{RV} = 0.47 \frac{c}{h_{nom}} - 0.17$$

$$C_{min} = h_{nom}, C_{sp} = 2.5 \cdot h_{nom}$$

### Recombined loads with influence of edge distance:

There must be reinforcement in the edge of a concrete component which can take up 0.25 times the anchor load if the edge distance is equal to or less than C<sub>sp</sub>.

$$f_{R\alpha} = f_{RN} - (f_{RN} - f_{RV}) \cdot \frac{\alpha}{90}$$

### Design resistance, R<sub>d</sub> [kN]: f<sub>ct</sub> = 30 N/mm<sup>2</sup>

Anchor size	M8	M10	M12	M16	M20
Tensile, N <sub>act</sub>	10.4	15.1	18.1	30.9	47.3
30°	11.9	17.9	24.1	41.3	64.6
45°	12.6	19.3	26.6	47.3	73.3
60°	13.4	20.7	29.1	52.7	82.0
90°	14.9	23.5	34.1	63.6	99.3

### Recommended load, F<sub>30</sub> in [kN], f<sub>cc</sub> = 30 N/mm<sup>2</sup>

Anchor size	M8	M10	M12	M16	M20
Tensile, N <sub>act</sub>	7.5	10.9	13.8	22.2	34.1
30°	8.5	12.8	17.3	30.0	46.3
45°	9.1	13.8	19.1	33.8	52.5
60°	9.6	14.8	20.8	37.7	58.9
90°	10.6	16.7	24.4	45.4	70.8

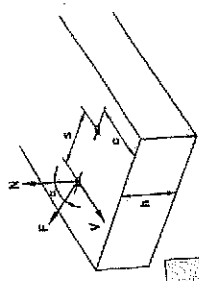

### Recommended load for specific application

$$F_{rec} = F_{cc} \cdot f_t \cdot f_A \cdot R$$

### f<sub>cc</sub> (kN): Load in different concrete strength

Anchor size	Concrete f <sub>cc</sub> [N/mm <sup>2</sup> ]	M8	M10	M12	M16	M20
20	7.1	9.8	11.4	17.5	27.0	
30	7.5	10.9	13.8	22.2	34.1	
40	7.9	11.9	16.1	26.9	41.2	
50	8.3	13.0	18.5	31.7	48.3	
55	8.5	13.5	19.7	34.0	51.9	
≥ 20	10.6	16.7	24.4	45.4	70.8	

### f<sub>t</sub>: influence of anchorage depth

$$f_t = \frac{h_{act}}{h_{nom}} \quad h_{nom} \geq h_{act} \geq 1.5 \cdot h_{nom}$$

Anchor size	M8	M10	M12	M16	M20
h <sub>nom</sub> [mm]	85	75	80	105	130



# HILTI

HSL-G-R heavy-duty anchor

### Setting details

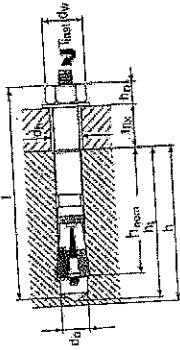

HSL-G-R

Setting details	M 8/20	M 8/40	M 10/20	M 10/40	M 12/25	M 12/50	M 16/25	M 16/50	M 20/30	M 20/60
Drill bit diameter	12	15	15	18	18	24	24	24	28	28
Hole depth	60	90	90	100	100	125	125	125	130	130
Min. anchorage depth	65	75	75	80	80	105	105	105	110	110
Max. fixture thickness	20	40	40	25	50	25	50	30	60	60
Anchor length	102	122	115	135	125	150	157	152	190	220
Flange height + washer	9.5	12.0	12.0	15.0	15.0	19.0	19.0	19.0	22.0	22.0
Tightening torque	4	25	40	80	80	120	120	120	200	200
Width across flats	13	17	17	19	19	24	24	24	31	31
Clearance hole	14	17	17	20	20	26	26	26	40	45
Washer diameter	20	25	25	30	30	40	40	40	220	220
Min. base material thickness	120	140	140	160	160	180	180	180	220	220
Drill bit	TE-CX	12/22	15/27	18/32	18/32	24/32	24/32	24/32	28/32	28/32
Drill bit	TE-T									

### Installation equipment

Rotary hammer (TE1, TE2, TE5, TE6, TE6A, TE15, TE15-C, TE18-M, TE35, TE55, TE76), a hammer and a torque wrench.

### Setting operations

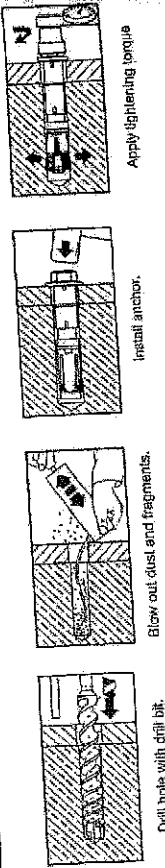

Drill hole with drill bit.

Blow out dust and fragments.

Install anchor.

Apply tightening torque

### Anchor mechanical properties

Anchor size	M 8	M 10	M 12	M 16	M 20
$f_u$ [N/mm <sup>2</sup> ]	780	700	700	700	700
$f_y$ [N/mm <sup>2</sup> ]	450	450	450	480	480
$A_s$ [mm <sup>2</sup> ]	36.6	58.0	84.3	157	245
$R_m$ [Nm]	108	231	390	865	1421
$M_4$ [Nm]	41	90	150	375	550

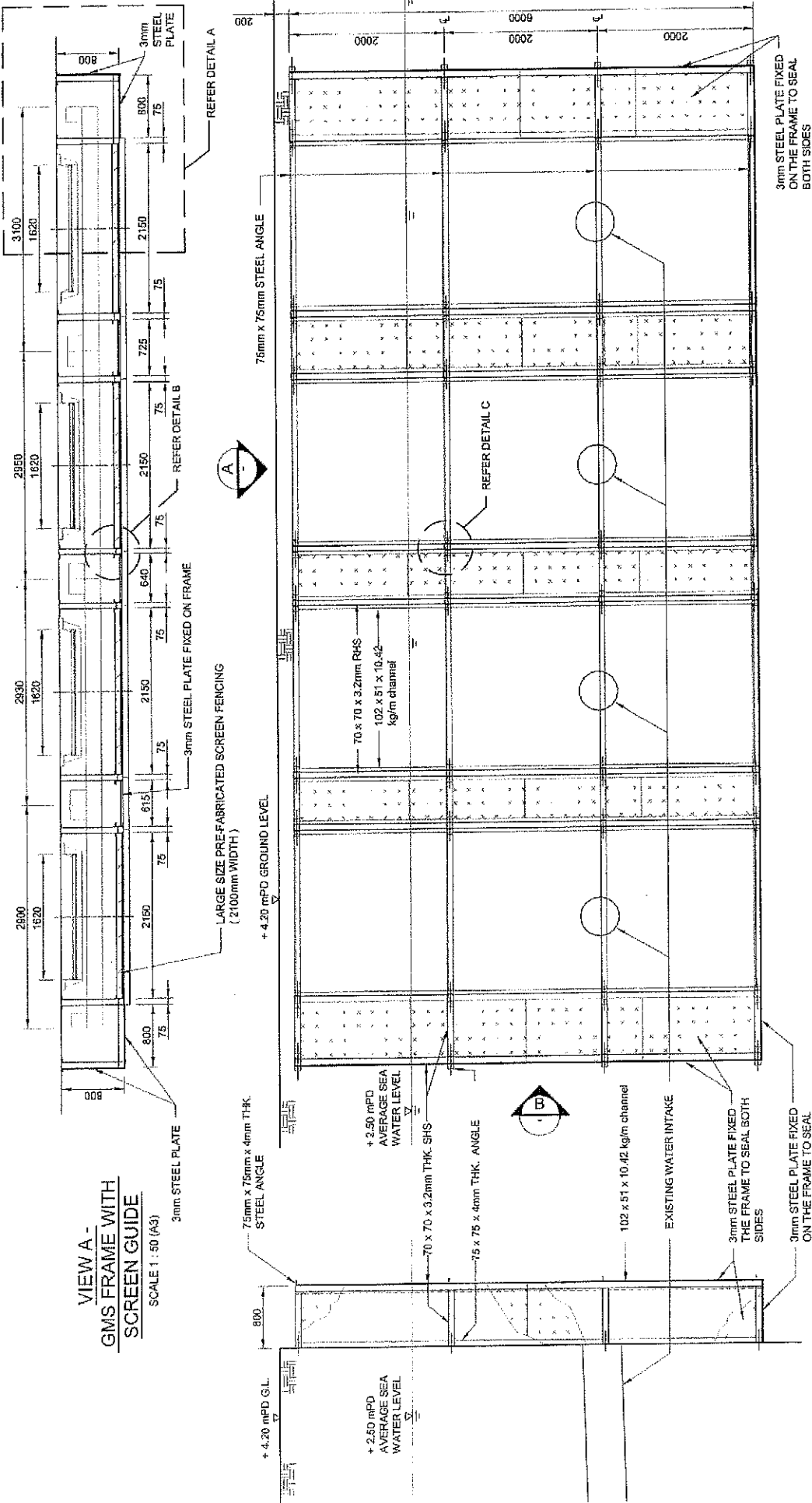

CLIENT <b>GEDD</b> Civil Engineering and Development Department	CONTRACTOR <b>俊和 - 中國中鐵聯合</b> CIUN WO - CRGL JOINT VENTURE	JOB TITLE: <b>PROPOSED WSD INTAKE COVER</b>		SCALE	A3 SHOWN (A3)	REF. TO DWG NO.	CW-CR/ENG/ENG-0105-R01.3					
		ENGINEER REPRESENTATIVE <b>AECOM</b>	PROJECT: WAN CHAI DEVELOPMENT PHASE II - CENTRAL - WAN CHAI BYPASS AT WAN CHAI EAST (HK200902)	DATE	30 MAR 2010	DRAWN	M.S. SIN	DESIGNED	SHEET NO	of	SHEET	
				CHECKED	-	APPROVED		SKETCH NO	EWCRJIV/HK200902/SK0022		REV	6



NOTE:  
ALL CONNECTION OF STEEL MEMBER BY  
4mm FILLET WELD, UNLESS OTHERWISE  
STATED.

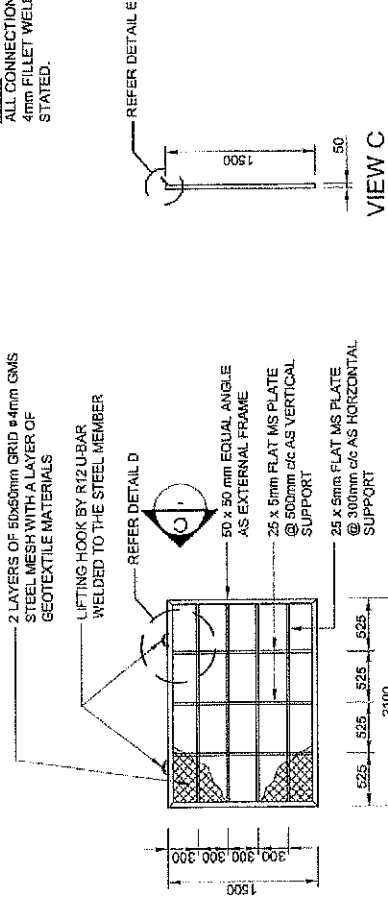

PRE-FABRICATED SILT SCREEN FENCING  
( 2100mm WIDTH )  
SCALE 1 : 50 (A3)

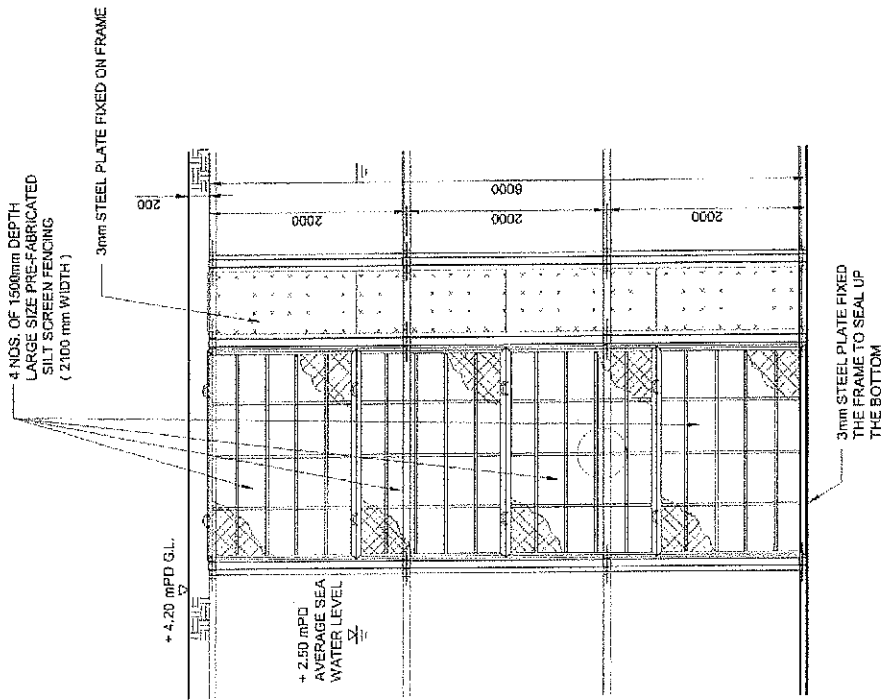

TYPICAL ARRANGEMENT OF SILT SCREEN FENCING  
INSTALLATION INTO THE WALL MOUNTED FRAME  
SCALE 1 : 50 (A3)

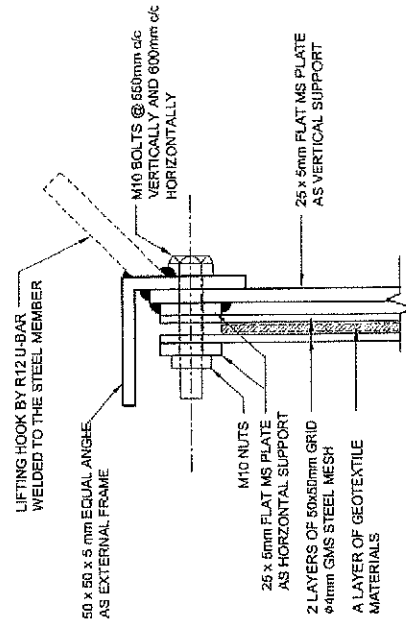
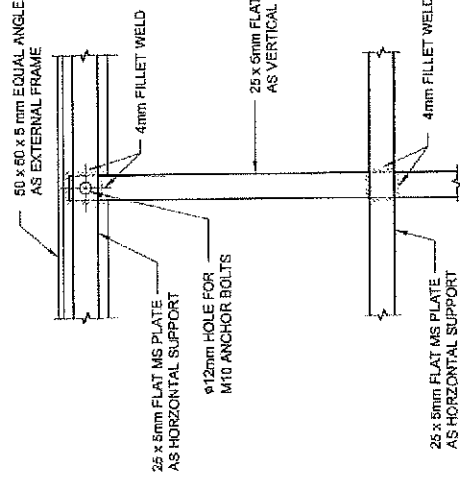

Client	土木工程發展處 CEDD Civil Engineering and Development Department	中環中環聯習 CHUN WO - CHUNG LUN VENTURE	REF. TO	CW-CR/ENG/ENG-0107-RD15
			AS SHOWN (A3)	
Contractor	AECOM	灣仔發展二期 WAN CHAI DEVELOPMENT PHASE II - CENTRAL - WAN CHAI BYPASS AT WAN CHAI EAST (HK200902)	DATE	30 MAR 2010
			DESIGNED	
Engineer's Representative			CHECKED	-
			APPROVED	
JOB TITLE			SHEET NO	of
PROPOSED PRE-FABRICATED SILT SCREEN FENCING AND THE TYPICAL ARRANGEMENT FOR ITS INSTALLATION INTO THE WALL MOUNTED FRAME			SKETCH NO	
			CHECKED	REV
				B

NOTE:  
DIMENSION OF THE PRE-FABRICATED  
FRAME SHOULD BE ADJUSTED TO SUIT THE  
ACTUAL SIZE OF EACH WATER INTAKE.

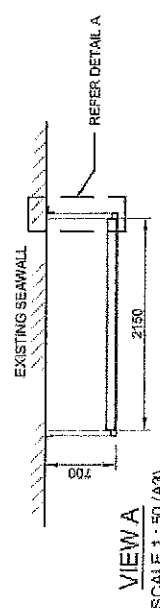

VIEW A  
SCALE 1:50 (A3)

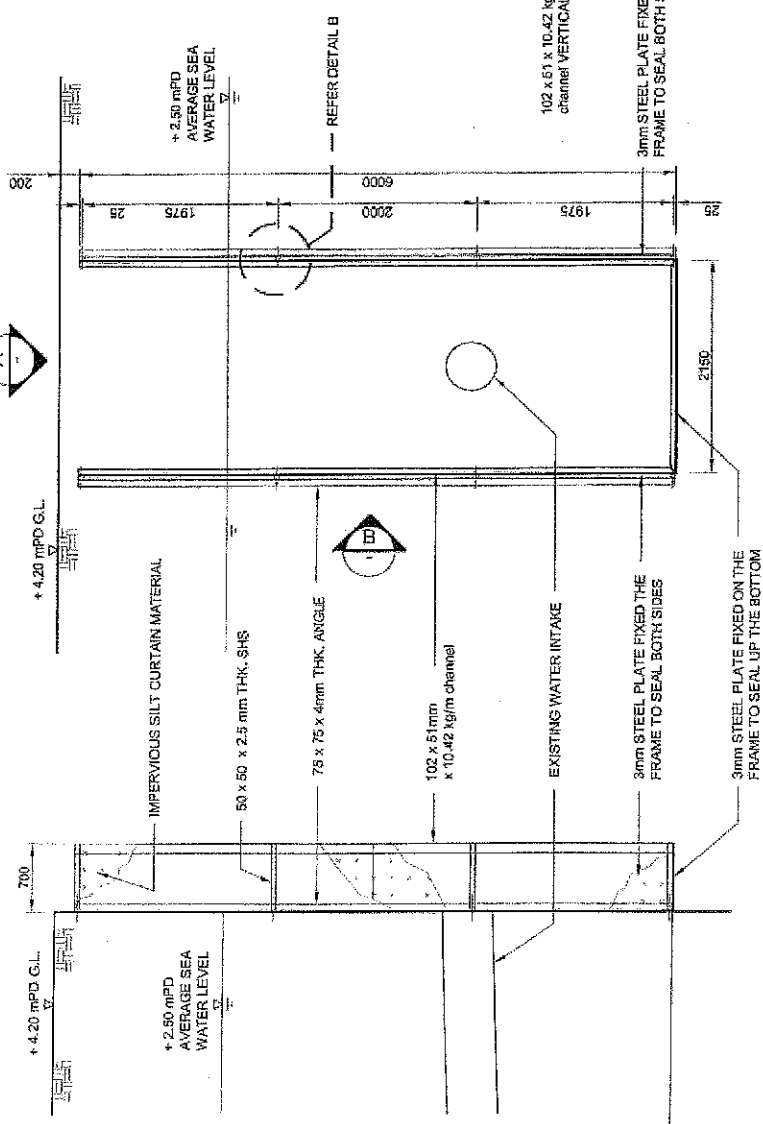

VIEW B  
SCALE 1:50 (A3)

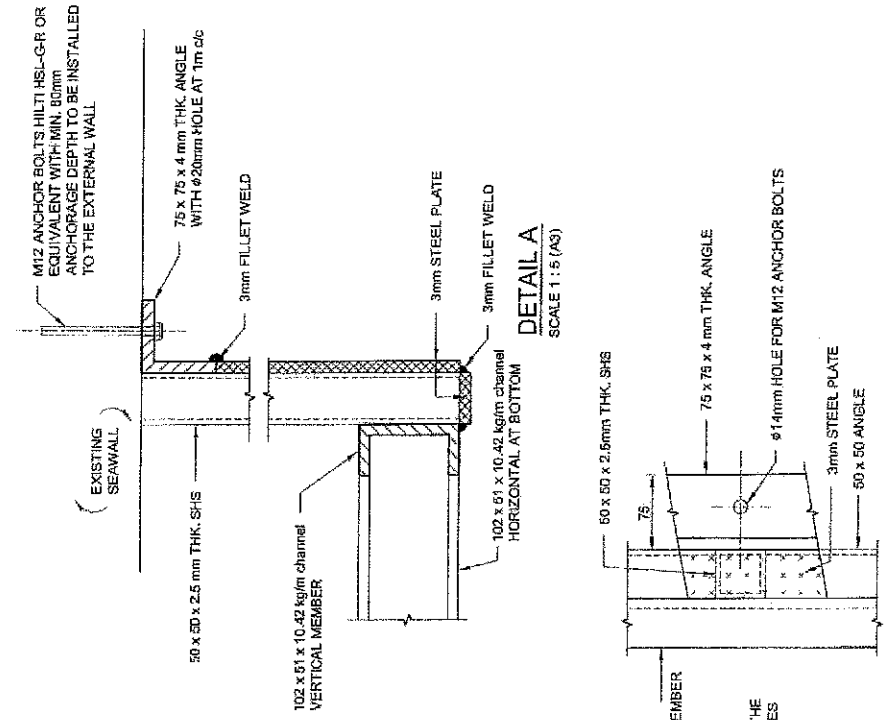

DETAIL A  
SCALE 1:5 (A3)

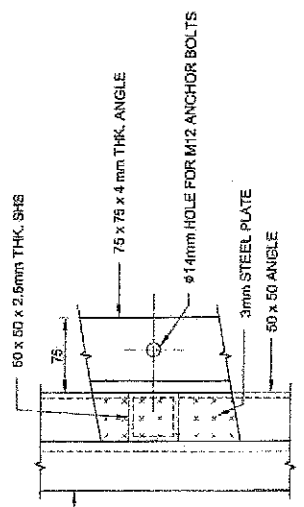

DETAIL B  
SCALE 1:5 (A3)

PRE-FABRICATED WALL MOUNTED FRAME  
FOR THE SILT SCREEN  
SCALE 1:50 (A3)

CLIENT CEDD Civil Engineering and Development Department AECOM ENGINEER'S REPRESENTATIVE	CONTRACTOR 俊和 - 中國中鐵聯營 CHUN WO - CREL JOINT VENTURE	JOB TITLE: FIXING DETAILS OF THE WALL MOUNTED STEEL FRAME TO THE EXTERNAL WALL OF SUN HUNG KEI PUMP STATION INTAKES		SCALE AS SHOWN (A3)	REF. TO DWD NO.	CMC-CR/ENG/SK/0025
		DATE 11 MAR 2010	DRAWN MS SIN	DESIGNED APPROVED	SHEET NO CMCRA/WHK2009/28/SK/025	of

NOTE:  
ALL CONNECTION OF STEEL MEMBER BY  
4mm FILLET WELD UNLESS OTHERWISE  
STATED.

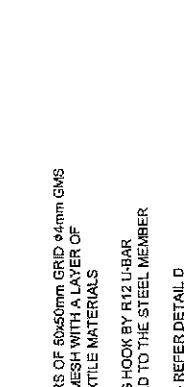

VIEW C  
SCALE 1 : 50 (A3)

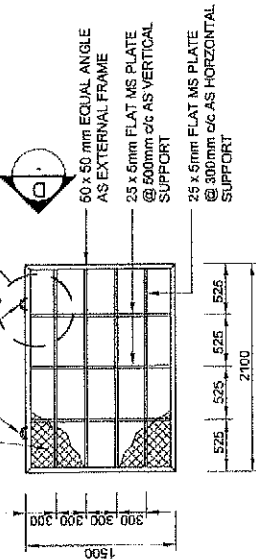

VIEW D  
SCALE 1 : 50 (A3)

**PRE-FABRICATED SILT SCREEN FENCING  
(2100mm WIDTH)**

SCALE 1 : 50 (A3)

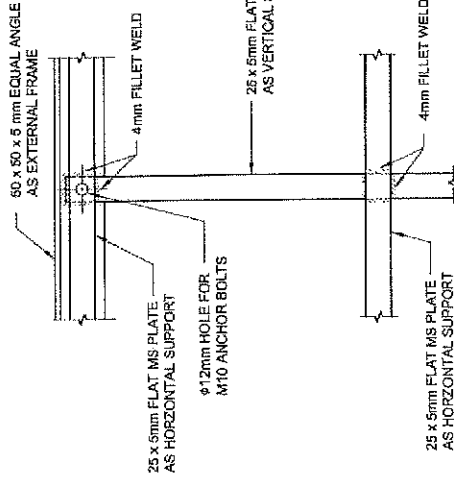

DETAIL C  
SCALE 1 : 5 (A3)

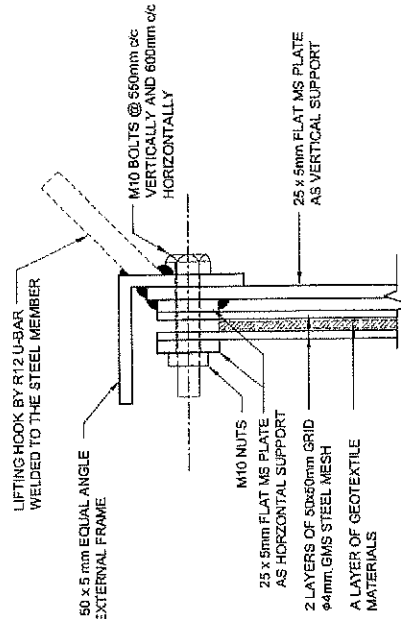

DETAIL D  
SCALE 1 : 2 (A3)

**TYPICAL ARRANGEMENT OF SILT SCREEN FENCING  
INSTALLATION INTO THE WALL MOUNTED FRAME**

SCALE 1 : 50 (A3)

JOB TITLE:

PROPOSED PRE-FABRICATED SILT SCREEN FENCING AND  
THE TYPICAL ARRANGEMENT FOR ITS INSTALLATION  
INTO THE WALL MOUNTED FRAME

JOB TITLE:

CONTRACTOR  
CHUN HO - 中國中環聯營  
CHUN HO - CHUN JOINT VENTURE

ENGINEER REPRESENTATIVE  
CEDD Civil Engineering and  
Development Department

PROJECT  
CONTRACT NO. HK2003/02  
WAN CHAI DEVELOPMENT PHASE II -  
CENTRAL - WAN CHAI BYPASS AT WAN CHAI EAST

AECOM

CUSH

SCALE AS SHOWN(A3)  
DATE 11 MAR 2010  
DRAWN MS SIR  
DESIGNED  
CHECKED : XXXY  
APPROVED

REF. TO DWG NO.

CW-CR/ENG/SK-SK0026

Sheet of

SKETCH NO

REV

CWCR/CHK/2009/2/SK0026

B

**9.3 Appendix C**  
**– Graphical Illustration for the**  
**Installations of the Silt Screen**  
**System**

## Graphical Illustration for Installation of Wall Mounted Frame

1. Switch off the relevant intake pump
2. Lift the pre-fabricated steel frame to the required position

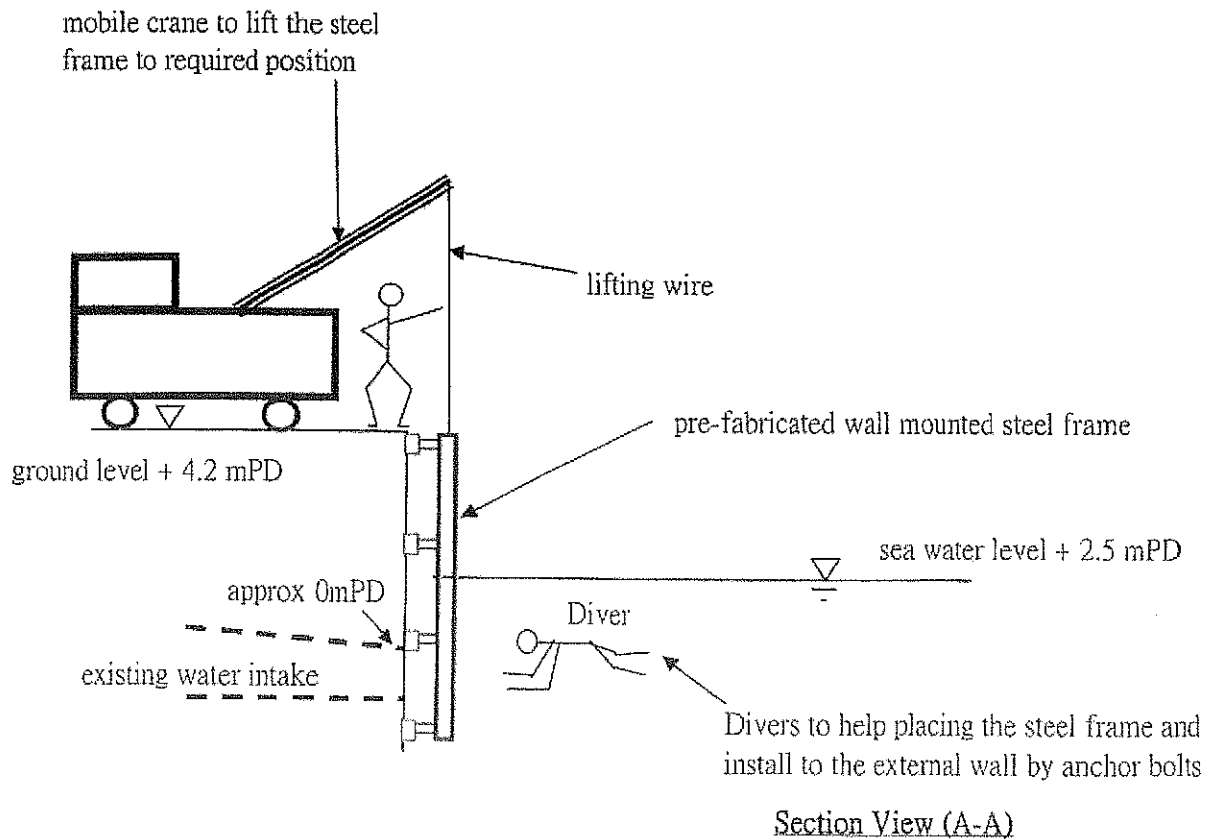
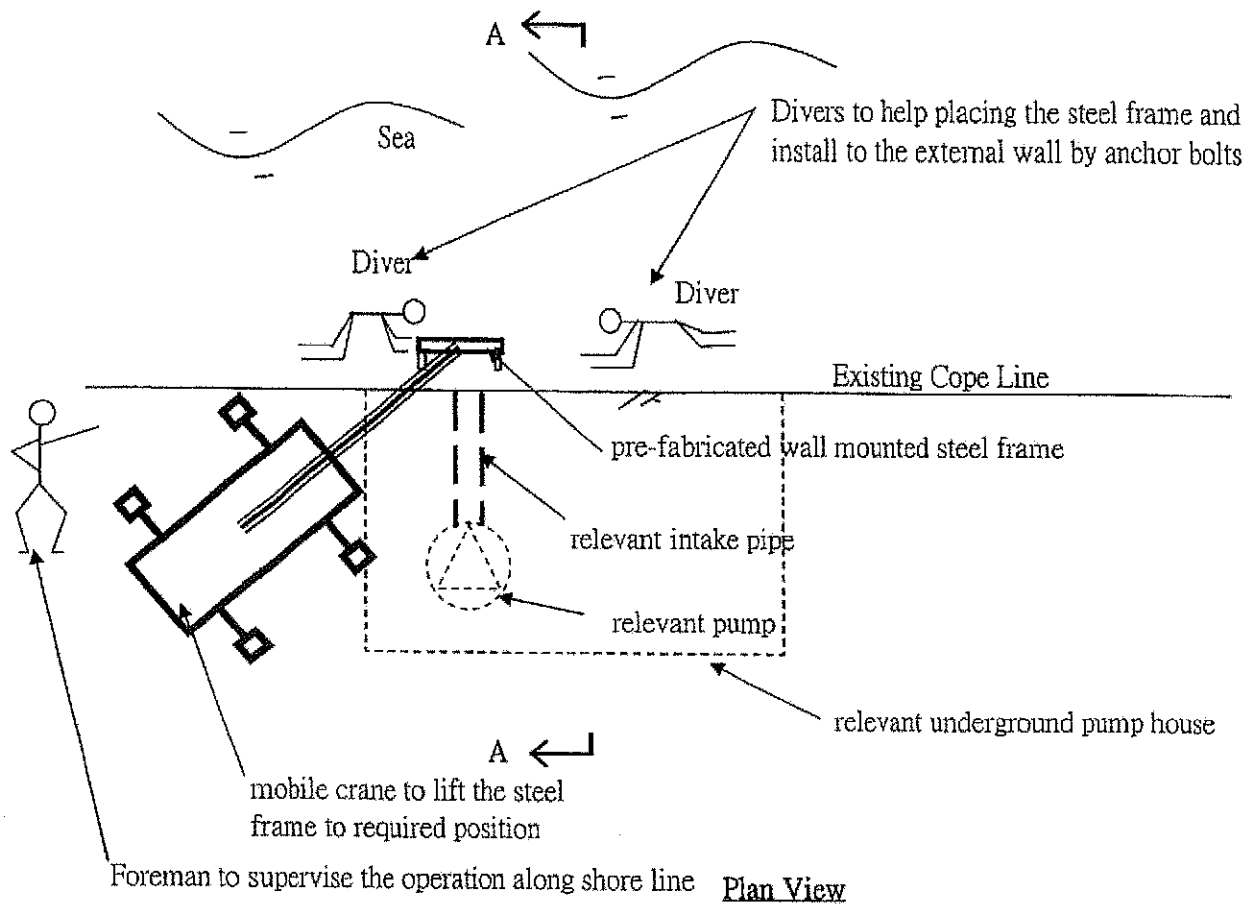



### Graphical Illustration for Installation of Wall Mounted Frame

3. Drill holes to the external wall by pneumatic air driller and install Hilti type HSL-3 bolts

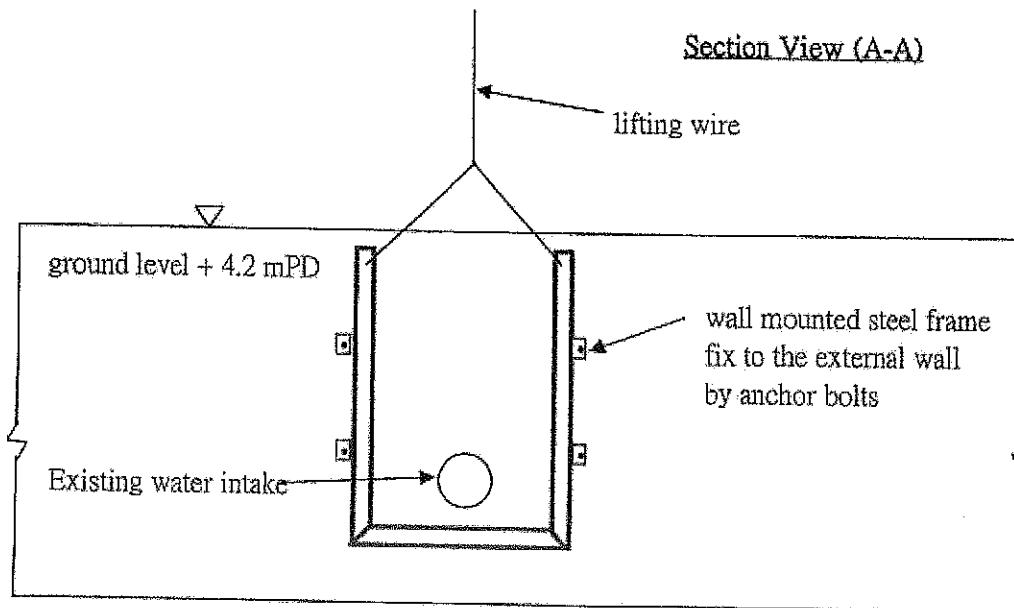
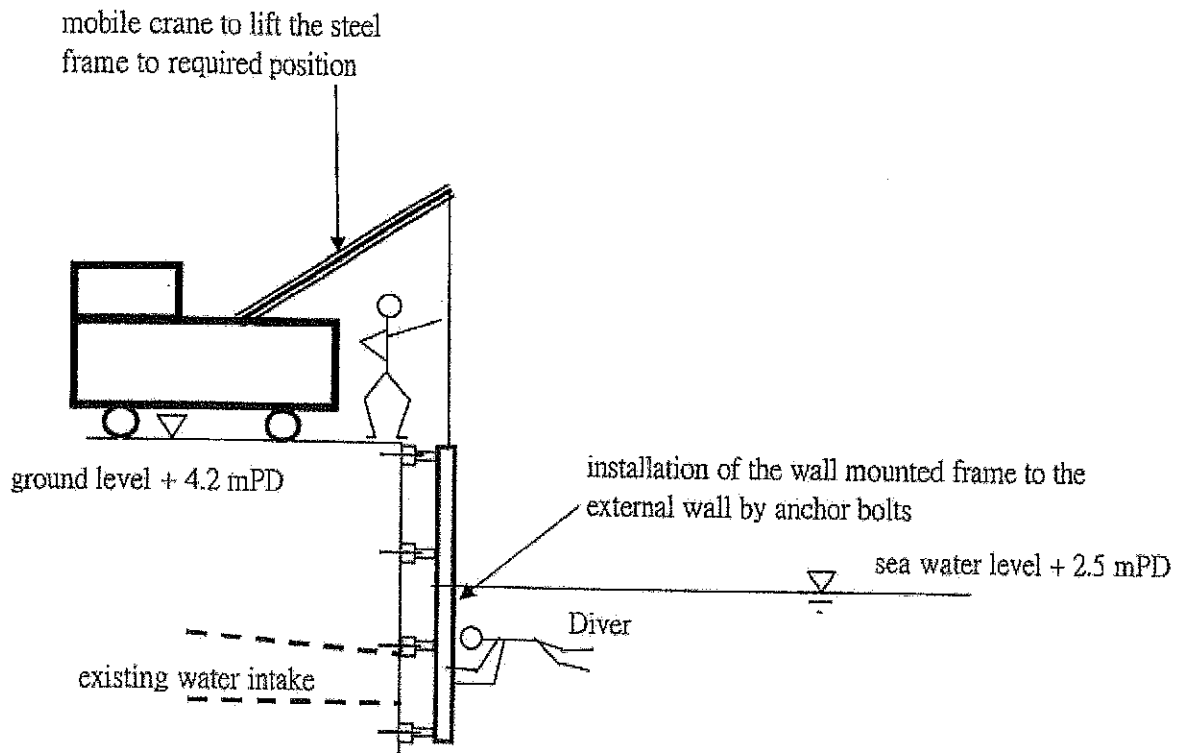

Elevation View

## Graphical Illustration for Installation of the Silt Screen Fencing

1. Switch off the relevant intake pump
2. Lift the pre-fabricated silt screen fencing (bottom piece) to the required position and insert into the frame
3. Maintain a steel wire at the lifting eye of the steel fence and bring it to ground
4. Lift the other piece of pre-fabricated silt screen fencing (upper piece) and insert into the wall mounted frame
5. Maintain another piece of steel wire at the lifting eye of the steel fence and bring it to ground
6. Tie the two piece of steel wire properly at existing lifting arm of the pump house for ease of later maintenance use
7. Later maintenance would be carried out by lifting up the steel fencing by using typical chain block pulley system

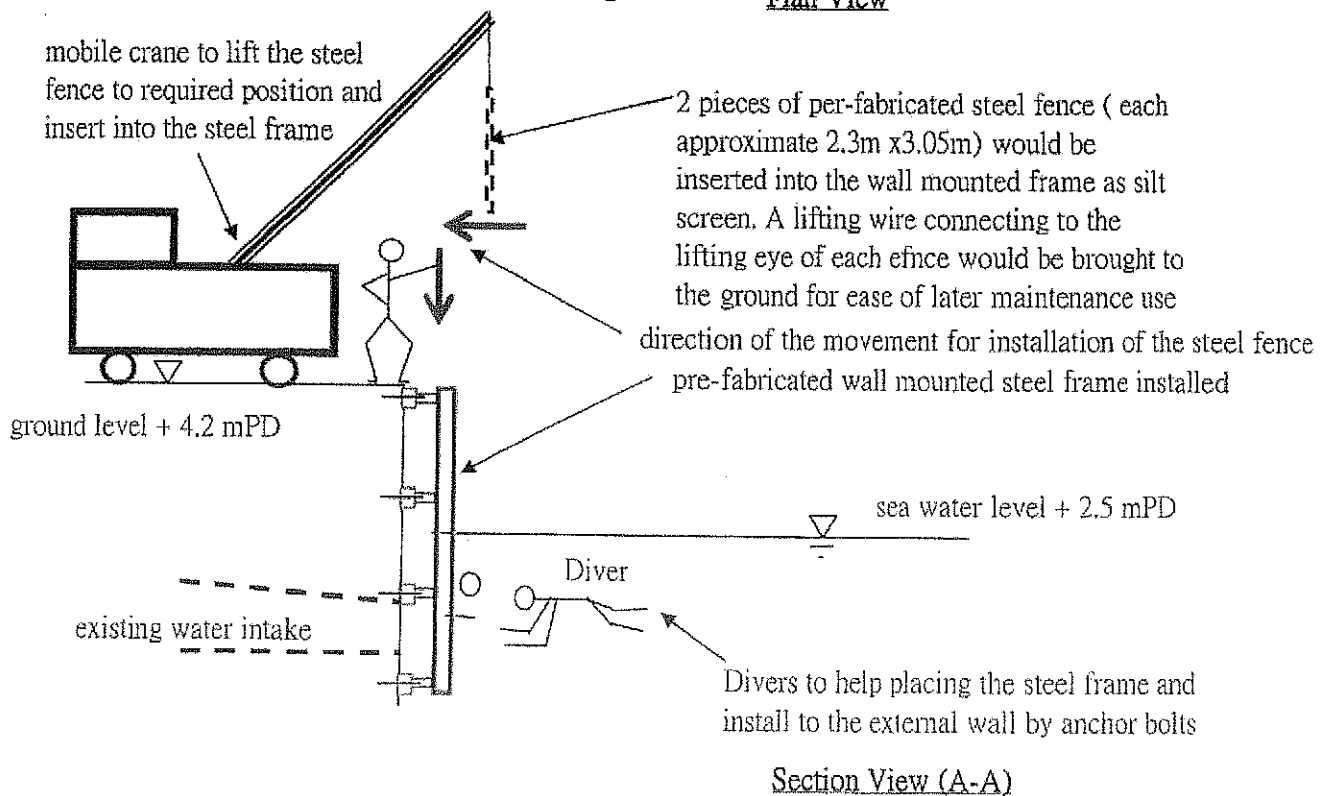
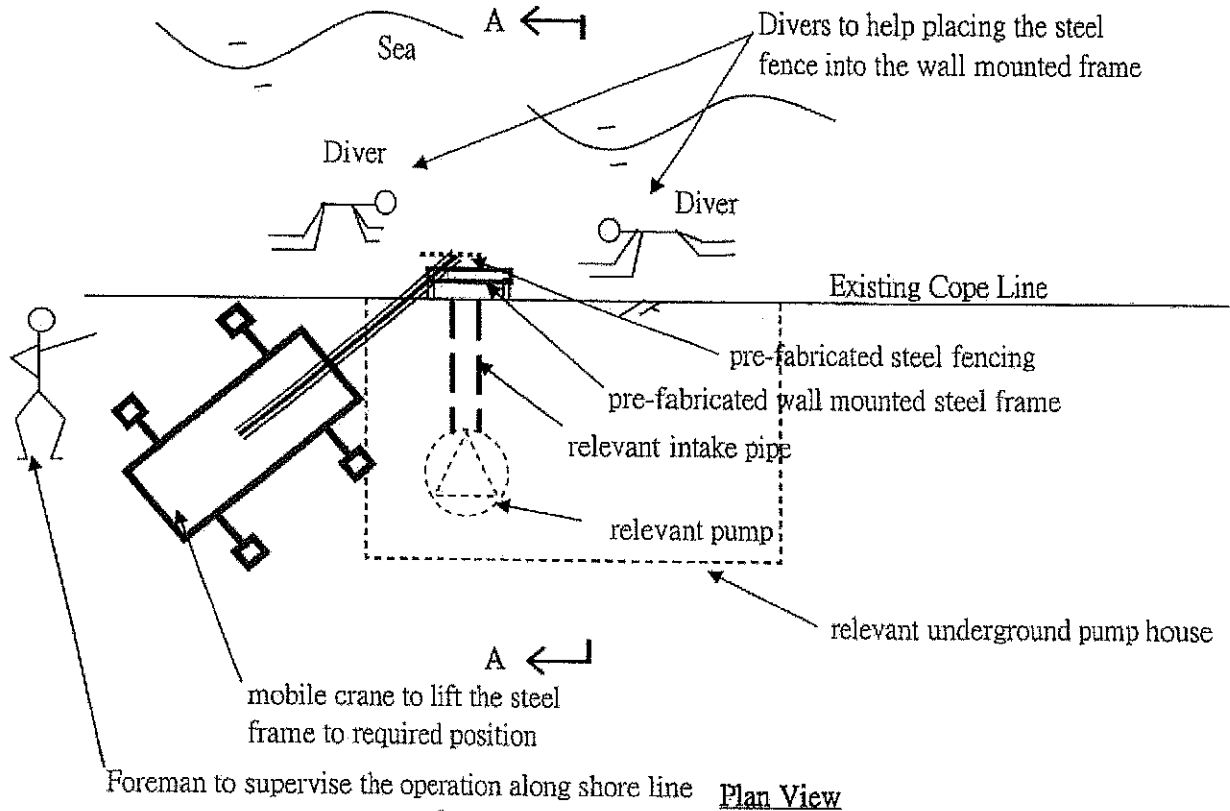

**9.4 Appendix D**  
**– Daily Inspection Checklist**



俊和 - 中國中鐵聯營  
CHUN WO - CRGL JOINT VENTURE

Contract No. HK/2009/02

Contract Title Wan Chai Development Phase II - Central - Wan Chai By Pass at Wan Chai East

Silt Screen 每日檢查表

說明：  
 ✓ = 滿意  
 ✕ = 不滿意，須改善  
 - = 不適用

位置：\_\_\_\_\_

日期：\_\_\_\_\_ 檢查員：\_\_\_\_\_

	星 期 一	星 期 二	星 期 三	星 期 四	星 期 五	星 期 六
<b>整潔</b>						
1. 沒有垃圾在架內						
2. 沒有泥水在架內						
3. 已清理架內垃圾						
其他問題(請註明)：						
<b>鐵架狀況</b>						
1. 鐵架沒有損壞						
2. 鐵網沒有損壞						
3. 繫緊螺絲沒有鬆脫						
其他問題(請註明)：						
<b>隔泥布狀況</b>						
1. 隔泥布沒有損壞						
2. 沒有隔泥布在業主的隔泥網上						
3. 隔泥布沒有鬆脫						
其他問題(請註明)：						
簽署：						

**9.5 Appendix E**  
**– Technical Properties of the**  
**Geotextile Material – Tencate**  
**Mirafi FW300**

# Mirafi® FW Woven Filter Geotextiles

## Properties of Mirafi® FW Woven Filter Geotextiles

Property	Unit	FW300	FW400	FW402	FW404	FW700
<b>Mechanical properties</b>						
<b>Wide width tensile strength</b>						
ISO 10319, ASTM D4595						
Mean tensile strength	MD kN/m	45	35	45	45	45
Mean tensile strength	CD kN/m	45	35	30	45	30
<b>Grab tensile strength</b>						
ASTM D4632						
Mean tensile strength	MD kN	1.8	1.4	1.8	1.8	1.7
Mean tensile strength	CD kN	1.5	1.2	0.9	1.5	1.1
Extension at peak strength	MD %	20	20	25	20	25
Extension at peak strength	CD %	20	20	20	20	20
<b>GBR puncture strength</b>						
ISO 12236, ASTM D6241						
Mean puncture strength	kN	5.5	4.5	3.0	5.5	4.5
<b>UV resistance after 500 hrs</b>						
ASTM D4355						
Strength retention	%	90	90	90	90	90
<b>Hydraulic properties</b>						
<b>Characteristic opening size</b>						
ISO 12856						
$O_{90}$	mm	0.35	0.30	0.25	0.20	0.20
<b>Percent open area</b>						
CDE-22125*86						
POA	%	10	10	10	-	-
<b>Water permeability</b>						
ISO 11059						
Mean flow rate, $Q_{50}$	l/m <sup>2</sup> /s	90	50	100	45	20
Mean permeability, $\psi$	s <sup>-1</sup>	1.8	1.0	2.0	0.9	0.4
Mean permeability/velocity index, $k_v$	cm/s	0.15	0.04	0.15	0.08	0.02
Nominal roll width	m	4.0	4.0	4.0	4.5	3.8
Nominal roll length	m	100	100	100	100	100
Estimated roll weight	kg	110	75	86	130	80

\* The mean flow rate is 90l/m<sup>2</sup>/s which is capable to allow normal operations of the pump houses.

Mirafi® is a registered trademark of Royal Ten Cate. The information contained herein is to the best of our knowledge accurate, but since the circumstances and conditions in which it may be used are beyond our control we do not accept any liability for any loss or damage, however arising, which results directly or indirectly from use of such information nor do we offer any warranty or immunity against patent infringement.

Ten Cate Industrial (China) Co., Ltd.  
South of Nongang West Road,  
Gaojian Port Economic Zone, Zhuhai 519050, China  
Tel: +86 756 336 1815, Fax: +86 756 060 1510  
Email: info.zhuhai@tencate.com

Ten Cate Geosynthetics Asia Sdn. Bhd.  
14, Jalan Somenia 27/51, Seksyen 27,  
40400 Shah Alam, Selangor Darul Ehsan, Malaysia  
Tel: +60 3 5192 8880, Fax: +60 3 5192 8575  
Email: info.asia@tencate.com

 **TENCATE**  
materials that make a difference



FILTRATION



SEPARATION



EROSION PROTECTION

## Mirafi® FW-Series Woven Geotextiles for Engineered Filtration

TenCate™ develops and produces materials that function to increase performance, reduce costs and deliver measurable results by working with our customers to provide advanced solutions.

The Difference Mirafi® FW-Series Engineered Filtration Geotextiles Make:

- **Engineered Filtration.** Resists clogging while maintaining flow rates in high gradient and dynamic flow conditions.
- **Durability.** High survivability rating in aggressive installation and loading conditions along with excellent resistance to chemicals in aggressive environments.
- **Soil Interaction.** Superior soil confinement resulting in greater load distribution.
- **Unique Constructions.** Manufactured with highly UV stabilized monofilament and multifilament fibers which provide highly uniform opening size (AOS) while maintaining high long-term flow rates. Mirafi® FW-Series geotextiles are manufactured with highly specialized processes to produce unique physical and hydraulic properties not possible with standard geotextiles, woven or nonwoven.

- **Seams.** Panels can be sewn together in the factory or field, providing cross-roll direction strength to facilitate installation.

### APPLICATIONS

Mirafi® FW-Series engineered filtration geotextiles are designed for long-term performance in problematic soil or site conditions to ensure clogging resistance, soil retention in erosion control, and subsurface drainage applications. Mirafi® FW-Series geotextiles are used underneath rip rap or concrete revetment systems along inland waterways and coastal shorelines to protect spillways and embankment dams from overtopping flow, encapsulating cut-off drains and collection systems surrounding landfills, filtration within dams. The geotextile is used adjacent to roadways and other critical structures, encapsulating leachate collection systems under landfills while maintaining long-term clogging resistance, and encapsulating edge drains for critical structures in problematic soils.

### INSTALLATION GUIDELINES\*

BANK STABILIZATION / ROCK (ARMOR) UNDERLAYMENT  
 Geotextile Placement

Place the geotextile in close contact with the soil, eliminating folds or excessive wrinkles

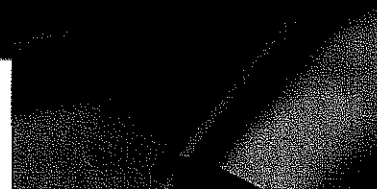

Mirafi® FW Woven Geotextile

both longitudinally and transversely. The geotextile need not be placed in tension before covering with riprap or other materials. Use care in placing the geotextile to avoid possible damage.

The geotextile can be joined by overlapping or sewing. Anchor the geotextile firmly at the top of the slope using an anchor trench. For maximum effectiveness, the trench should be at least 1m (3ft) from the crest of the slope and at least 0.6m (2ft) deep. Thoroughly compact soil in the trench to ensure good anchorage. When placing the geotextile along a stream or other places where water movements are expected, anchor the toe of the geotextile in a similar fashion as at the top to prevent scour beneath it.

\* These guidelines serve as a general basis for installation. Detailed instructions are available from your TenCate™ representative.

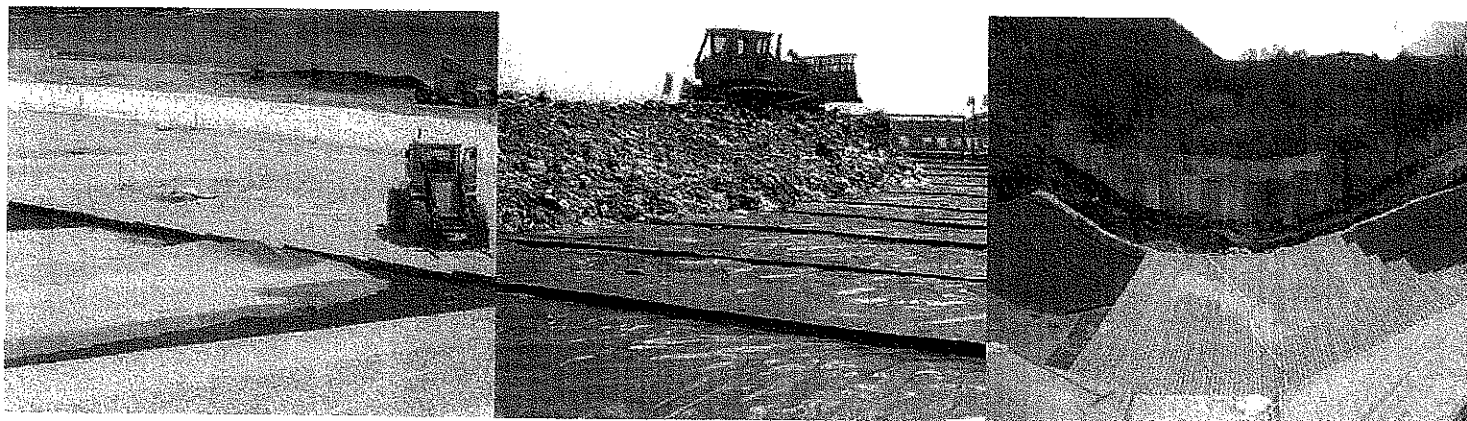

Protective & Outdoor Fabrics

Aerospace Composites

Armour Composites

Geosynthetics

Industrial Fabrics

Synthetic Grass

**Mirafi® FW Woven Geotextiles**  
for Engineered Filtration

Property / Test Method	Units	FW300	FW402	FW403	FW405	FW500	FW700
<b>MECHANICAL PROPERTIES</b>							
<b>Wide Width Tensile Strength</b>							
ASTM D 4595							
MD @ Ultimate	kN/m (lbs/ft)	40.3 (2780)	35.0 (2400)	47.3 (3240)	43.8 (3000)	32.1 (2196)	39.4 (2700)
CD @ Ultimate	kN/m (lbs/ft)	39.4 (2700)	24.5 (1680)	39.4 (2700)	40.3 (2760)	43.8 (3000)	25.4 (1740)
<b>Grab Tensile Strength</b>							
ASTM D 4632							
MD @ Ultimate	N (lbs)	1780 (400)	1624 (365)	1891 (425)	1780 (400)	1446 (325)	1.6 (370)
CD @ Ultimate	N (lbs)	1491 (335)	890 (200)	1558 (350)	1402 (315)	1891 (425)	1.1 (250)
MD Elongation @ Ultimate	%	15	24	21	15	15	15
CD Elongation @ Ultimate	%		10	21	15	15	15
<b>Trapezoidal Tear Strength</b>							
ASTM D 4533							
MD	N (lbs)	645 (145)	512 (115)	645 (145)	666 (150)	601 (135)	0.4 (100)
CD	N (lbs)	556 (125)	334 (75)	556 (125)	734 (165)	668 (150)	0.3 (60)
<b>Puncture Strength</b>							
ASTM D 4833							
	N (lbs)	556 (125)	401 (90)	668 (150)	668 (150)	632 (140)	0.5 (120)
<b>UV Resistance after 500 hrs.</b>							
ASTM D 4355							
	% Strength	90	90	90	90	70	90
<b>HYDRAULIC PROPERTIES</b>							
<b>Apparent Opening Size</b>							
ASTM D 4751							
	mm (US Sieve)	0.60 (30)	0.43 (40)	0.43 (40)	0.43 (40)	0.30 (50)	0.212 (70)
<b>Permittivity ASTM D 4491</b>							
	sec <sup>-1</sup>	1.50	2.1	0.96	0.90	0.51	0.28
<b>Percent Open Area</b>							
COE-02215-86							
	%	8	10	6	1	4	4-6
<b>Flow Rate</b>							
ASTM D 4491							
	l/min/m <sup>2</sup> (gal/min/ft <sup>2</sup> )	4685 (115)	5907 (145)	2852 (70)	2852 (70)	1426 (35)	733.3 (18)
<b>Packaging</b>							
Roll Width	m (ft)	3.9 (12.5)	3.8 (12.5)	3.8 (12.5)	4.5 (15)	3.7 (12)	3.7 (12)
Roll Length	m (ft)	91 (300)	91 (300)	91 (300)	91 (300)	91 (300)	91 (300)
Est. Gross Weight	kg (lbm)	100 (221)	76.6 (169)	110 (243)	132 (292)	96 (212)	74 (164)
Area	m <sup>2</sup> (yd <sup>2</sup> )	348 (417)	348 (417)	348 (417)	416 (500)	334 (400)	334 (400)

\*NOTE: Mechanical Properties and Hydraulic Properties shown are Minimum Average Roll Values (MARV). Apparent Opening Size (AOS) properties shown are Maximum Average Roll Values.  
NP - Not Published

**Mirafi® FW Woven Geotextiles**

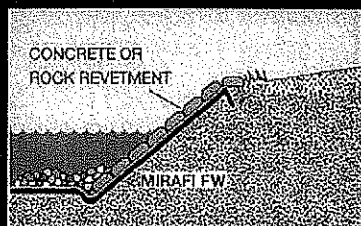

Shoreline Erosion Control

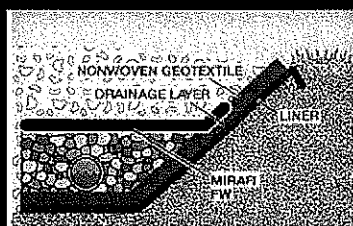

Leachate Collection System

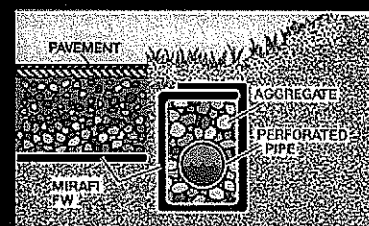

Cut-off/Interceptor Drain Along a Roadway

TenCate® Geosynthetics North America assumes no liability for the accuracy or completeness of this information or for the ultimate use by the purchaser. TenCate® Geosynthetics North America disclaims any and all express, implied, or statutory standards, warranties or guarantees, including without limitation any implied warranty as to merchantability or fitness for a particular purpose or arising from a course of dealing or usage of trade as to any equipment, materials, or information furnished herewith. This document should not be construed as engineering advice.

Mirafi® is a registered trademark of Nicolon Corporation.

PDS FW1009

365 South Holland Drive Tel 800 685 9990 Fax 706 693 4400  
Pendergrass, GA 30567 Tel 706 693 2226 www.mirafi.com



**TENCATE**  
materials that make a difference





# Mirafi



## Mirafi® FW300

Mirafi® FW300 geotextile is composed of high-tenacity monofilament polypropylene yarns, which are woven into a stable network such that the yarns retain their relative position. Mirafi® FW300 geotextile is inert to biological degradation and resists naturally encountered chemicals, alkalis, and acids.

Mechanical Properties	Test Method	Unit	Minimum Average Roll Value	
			MD	CD
Wide Width Tensile Strength	ASTM D 4595	kN/m (lbs/in)	40.3 (230)	39.4 (225)
Grab Tensile Strength	ASTM D 4632	N (lbs)	1780 (400)	1491 (335)
Grab Tensile Elongation	ASTM D 4632	%	20	15
Trapezoid Tear Strength	ASTM D 4533	N (lbs)	645 (145)	556 (125)
CBR Puncture Strength	ASTM D 6241	N (lbs)	5563 (1250)	
Apparent Opening Size (AOS) <sup>1</sup>	ASTM D 4751	mm (U.S. Sieve)	0.60 (30)	
Percent Open Area	COE-02215	%	8	
Permittivity	ASTM D 4491	sec <sup>-1</sup>	1.5	
Permeability	ASTM D 4491	cm/sec	0.13	
Flow Rate	ASTM D 4491	l/min/m <sup>2</sup> (gal/min/ft <sup>2</sup> )	4685 (115)	
UV Resistance (at 500 hours)	ASTM D 4355	% strength retained	90	

<sup>1</sup> ASTM D 4751, AOS is a Maximum Opening Diameter Value

Physical Properties	Test Method	Unit	Typical Value
Mass/Unit Area	ASTM D 5261	g/m <sup>2</sup> (oz/yd <sup>2</sup> )	271 (8.0)
Thickness	ASTM D 5199	mm (mils)	0.9 (35)
Roll Dimensions (width x length)	--	m (ft)	3.8 (12.5) x 91 (300)
Roll Area	--	m <sup>2</sup> (yd <sup>2</sup> )	348 (417)
Estimated Roll Weight	---	kg (lbs)	100 (221)

**Disclaimer:** TenCate assumes no liability for the accuracy or completeness of this information or for the ultimate use by the purchaser. TenCate disclaims any and all express, implied, or statutory standards, warranties or guarantees, including without limitation any implied warranty as to merchantability or fitness for a particular purpose or arising from a course of dealing or usage of trade as to any equipment, materials, or information furnished herewith. This document should not be construed as engineering advice.





**INSTALLATION GUIDELINES FOR  
GEOTEXTILES USED IN FILTRATION AND  
DRAINAGE APPLICATIONS**

**Prepared by**

**TenCate Geosynthetics North America  
365 South Holland Drive  
Pendergrass, GA 30567  
Tel: (706) 693-2226  
Fax: (706) 693-2044  
[www.mirafi.com](http://www.mirafi.com)**

# **INSTALLATION GUIDELINES FOR GEOTEXTILES USED IN FILTRATION AND DRAINAGE APPLICATIONS**

## **GENERAL**

This document is prepared to help ensure that a subsurface drainage geotextile, once installed, will perform its intended design function. To do so, the geotextile must be identified, handled, stored, and installed in such a way that its physical property values are not affected and that the design conditions are ultimately met as intended. This document contains information consistent with generally accepted methods of identifying, handling, storing and installing geotextile materials. Failure to follow these guidelines may result in the unnecessary failure of the geotextile in a properly designed application.

## **MATERIAL IDENTIFICATION, STORAGE AND HANDLING**

The geotextile shall be rolled on cores having strength sufficient to avoid collapse or other damage from normal use. Each roll shall be wrapped with a plastic covering to protect the geotextile from damage during shipping and handling, and shall be identified with a durable gummed label or the equivalent, clearly readable on the outside of the wrapping for the roll. The label shall show the manufacturer's name, the style number, and the roll number. Roll identification corresponding to the proposed location of the roll as shown on the construction drawings and as approved by the Engineer, Owner and Contractor can be provided.

While unloading or transferring the geotextile from one location to another, prevent damage to the wrapping, core, label, or to the geotextile itself. If the geotextile is to be stored for an extended period of time, the geotextile shall be located and placed in a manner that ensures the integrity of the wrapping, core, and label as well as the physical properties of geotextile. This can be accomplished by elevating the geotextile off the ground on dunnage and ensuring that it is adequately covered and protected from ultraviolet radiation including sunlight, chemicals that are strong acids or strong bases, fire or flames including welding sparks, temperatures in excess of 60°C (140°F), and human or animal destruction.

Before unrolling the geotextile, verify the roll identification, length, and installation location with the contract drawings. While unrolling the geotextile, inspect it for damage or defects. Repair any damage that occurs during storage, handling or installation as directed by the Engineer. Normally light traffic will not damage the exposed geotextile. However, as a safety precaution, it is recommended that traffic not run on exposed geotextile.

**TENCATE**  
**Mirafi**

**Mirafi® FW-Series Woven Geotextiles**  
**High Performance Filtration Fabric**



**TENCATE**  
materials that make a difference

# Mirafi® FW-Series Woven Geotextiles

## High Performance Filtration Fabric

### The Unique Product

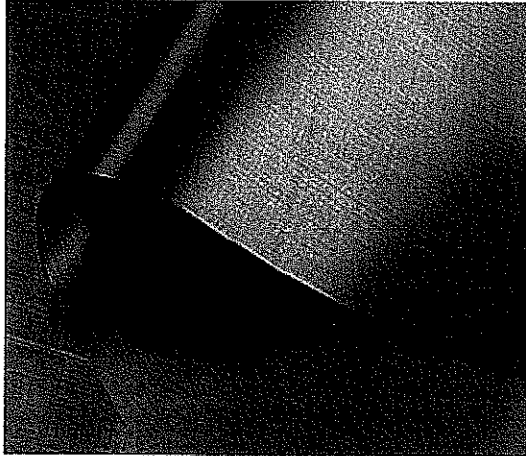

Mirafi® FW-Series geotextiles are manufactured using highly specialised fibre technology and processes to produce unique mechanical and hydraulic properties not possible with standard geotextiles, woven or nonwoven. The result is a series of geotextiles that combines the following benefits:

- High tensile strength
- High geotextile permeability
- High resistance to compression, thus permeability and pore size remain stable even when subject to high overburden loads
- Simple fabric structure that resists clogging while maintaining flow rates in high gradient and dynamic flow conditions
- Excellent durability and resistance to chemicals in aggressive environments
- Exceptionally high UV resistance
- Excellent survivability or damage resistance during installation

### The Functions Performed

When Mirafi® FW-Series geotextiles are placed in soil, hydraulic and environmental structures they fulfill a range of functions that enhance the performance of these structures.

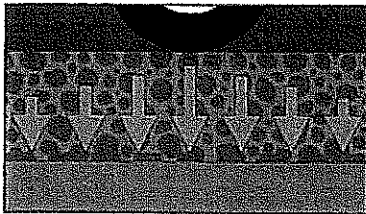

**Separation:** preventing the intermixing of soft foundation soils with granular materials thereby maintaining the structural integrity of the granular material.

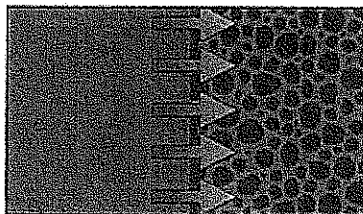

**Filtration:** allowing fluids to pass while preventing the migration of soil particles.

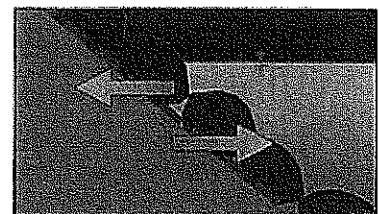

**Erosion control:** preventing the erosion of soil particles due to water flow, surface run-off, or wave and tidal action.

### Clogging Resistance

Experience have shown that geotextile clogging may be an important design consideration under the following filtration application operating environment:

- Poorly graded fine, cohesionless, soils such as loess, rock flour, and stone quarry fines
- Cohesionless soils consisting of gap-graded, particle-size distributions and functioning under high hydraulic gradients
- Dispersive clays that separate into individual fine particles over time
- High alkalinity groundwater where the slowing of the liquid when it flows through the filter geotextile can cause a calcium, sodium, or magnesium precipitate to be deposited
- High suspended solids in the permeating liquid, as found in turbid river water or dredged water that can build up on, or within, the filter geotextile
- High suspended solids coupled with high micro-organisms content, as in landfill leachates and agricultural wastes, can combine to build up on, or within, the filter geotextile

Mirafi® FW-Series geotextiles, with a simple and open structure, offers high permeability with no complex pore space to trap particles within. They have relatively much smaller specific surface area for chemical deposits and biofilm growth. Thus Mirafi® FW-Series geotextiles have superior resistance to clogging unmatched by any conventional geotextiles in the market.

# Subsurface Drainage Applications

Mirafi® FW-Series geotextiles are used as filter layer for a wide range of subsoil drainage structures; including trench drains, horizontal drainage blankets, vertical drainage behind retaining structures, chimney and toe drains to provide seepage control for earth dams and leveas. Due to their high permeability even when under low hydraulic gradient conditions, they are ideally suited for sports ground drainage applications, where it is important to be able to resume play within the shortest possible time after heavy rain.

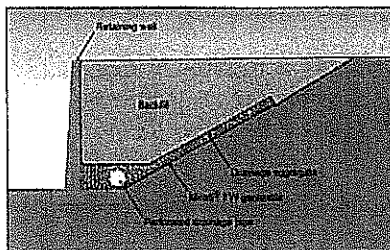

## GROUND WATER SEEPAGE CONTROL

The uncontrolled movement of groundwater can be detrimental to geotechnical structures by reducing effective shear strengths in soils, lubricating failure planes, contributing to liquefaction during earthquakes and promoting soil piping. Mirafi® FW-Series geotextiles are used as filters in subsoil drainage systems for even the most problematic soils as well as groundwater seepage conditions.

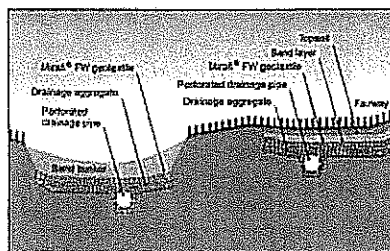

## RAINWATER INFILTRATION CONTROL

Sports grounds require drainage of surface ponding of water within the shortest possible lag time after rain for early resumption of use or play. Often, that requires a drainage blanket close to the ground surface, with a highly permeable and efficient filtration system as well as minimal clogging risk over time. Mirafi® FW-Series geotextiles are ideal candidates for such applications.

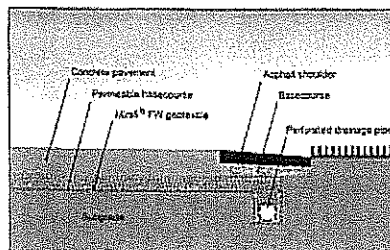

## PERMEABLE PAVEMENT BASECOURSES

For pavements designed with permeable basecourses, these basecourses need to function structurally as well as hydraulically to drain away surface infiltration and groundwater seepages from the subgrade. The high strength Mirafi® FW-Series geotextiles will provide excellent ground stabilisation benefits in addition to performing the filtration function required over the lifespan of the pavement.

# Marine Applications

In high gradient shoreline applications, the quick release of hydrostatic pressure through the geotextile is critical to long-term performance. Due to their low clogging potential, Mirafi® FW-Series geotextiles are also ideally suited as filter layers between soil and rock dykes as well as under armour protection layers. Mirafi® FW-Series geotextiles are extremely robust and can withstand high installation stresses. They can be easily prefabricated into large panels for quick deployment. This is done by seaming adjacent rolls of geotextiles to ensure structural continuity and integrity.

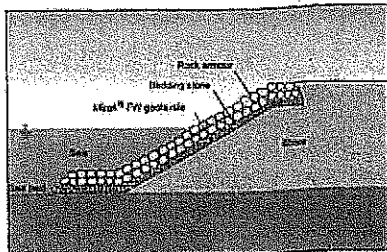
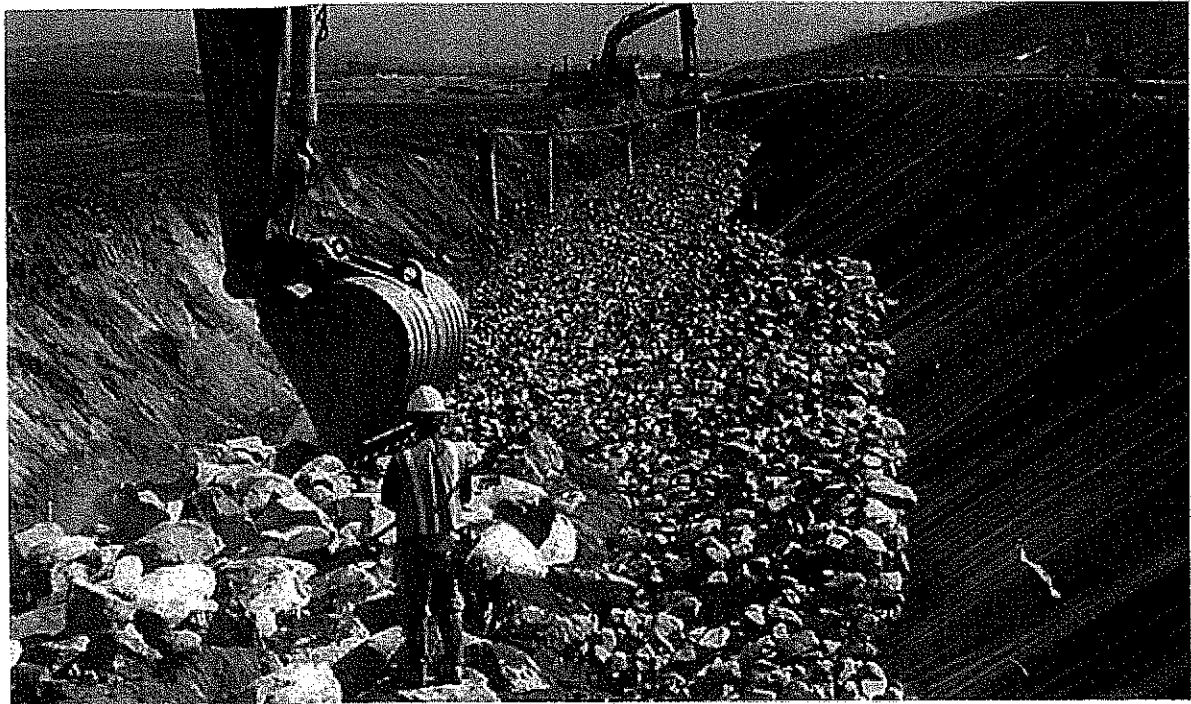

## REVETMENTS

Mirafi® FW-Series geotextiles are uniquely engineered filter geotextiles that exhibit a consistent and simple pore structure along with high permeability. This makes them suitable as revetment filters for problematic soils and sands in difficult environments where quick and unimpeded release of pore water pressure is required. Mirafi® FW-Series geotextiles can be installed with ease. They have excellent resistance against ultraviolet radiation to ensure minimal loss of strength during installation exposure.

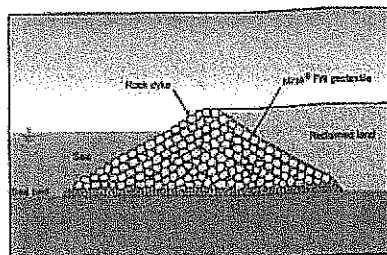

## RECLAMATION DYKES

Dykes prevent soil washout by waves and currents during land reclamation works in marine environment. Mirafi® FW-Series geotextiles prevent the loss of reclamation fill through the permeable reclamation dykes, which can be an important issue especially in an environmentally sensitive area. Mirafi® FW-Series geotextiles with high permeability will ensure rapid dewatering of dredged reclamation fill.

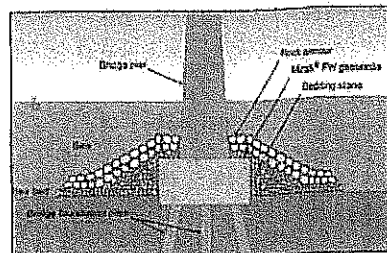

## SCOUR PROTECTION LAYERS

Mirafi® FW-Series geotextiles act as filtration layer underneath scour protection armour layers. They can be prefabricated into large and unique paneling for easy underwater deployment. The high tensile strength and robust Mirafi® FW-Series geotextiles can resist high installation stresses that are normally associated with underwater installation of filtration geotextiles.

# Landfill Applications

Mirafi® FW-Series geotextiles with high tensile strength are used as support layers over soft subgrades, where they act as separator and filter, before landfill liner systems are constructed. Due to their low clogging potential, they are also ideally suited as leachate filter layers prior to placement of solid wastes. Planar drainage geocomposites are often used for subsoil drainage, gas transmission and leachate detection in liner systems in landfills. Mirafi® FW geotextiles will resist caving into the drainage core space even under high compression load and are the ideal geotextiles for fabrication of the drainage composites.

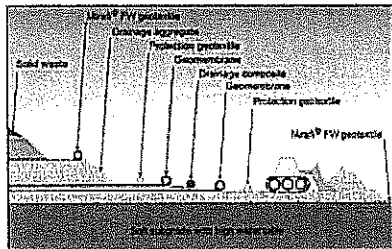

## SUBGRADE STABILISATION AND DRAINAGE LAYER FILTRATION

For landfills constructed on soft ground, subgrades may need to be stabilised prior to installation of liner systems. Often, the subgrade stabilisation platform layer is required to perform a long term subsoil drainage function as well. Mirafi® FW-Series geotextiles with high tensile strength and good hydraulic properties are ideal for soft subgrade stabilisation cum drainage layer filtration in landfill engineering.

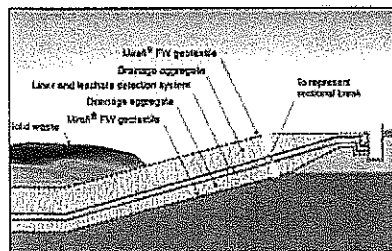

## LEACHATE FILTRATION

Studies have shown that the magnitude of decrease in leachate filtration geotextile permeability in landfills depends on the openness of the geotextile, the flow rate and the concentration of the leachate. Mirafi® FW-Series geotextiles engineered with even pore sizes and a high degree of openness are the geotextiles of choice for leachate filtration in landfills.

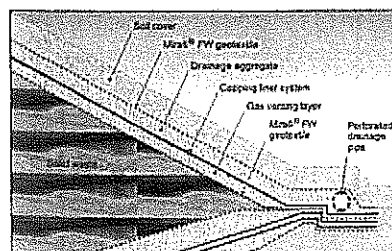

## LANDFILL COVER SYSTEMS

The primary purpose of a landfill cover is to isolate waste materials from the environment by minimising the infiltration of surface water, preventing human and animal contact with waste materials, and controlling landfill gases. Mirafi® FW-Series geotextiles are ideal as filters used within cover systems for rapid removal of infiltrating water as well as generated gases from the decomposing waste matters within the landfills.



# Filtration Design<sup>(1)</sup>

## Hydraulic design criteria

There are two fundamental geotextile properties that govern how it behaves hydraulically, namely opening size (relating to the soil retention criterion) and water permeability (relating to the permeability criterion). Table 1 may be used for the hydraulic design of Mirafi® FW-Series woven geotextiles as filters and are applicable for subsurface drainage and marine applications.

Table 1: Hydraulic Design Criteria for Mirafi® FW-Series Woven Geotextiles		
1. Soil retention where the soil to be filtered is predominantly granular soil where the soil to be filtered is predominantly silty soil where the soil to be filtered is predominantly cohesive soil	Drainage applications	Marine applications
	$O_{50} \leq D_{85}$	$O_{50} \leq D_{50}$
	$O_{80} \leq 2D_{85}$	$O_{80} \leq D_{50}$
	$O_{90} \leq 0.22\text{mm}$	$O_{90} \leq 0.22\text{mm}$
2. Permeability	$k_0 \geq A k_s$	$k_0 \geq k_s$

Notes:

- (a)  $k_0$  denotes the geotextile permeability or velocity index
- (b)  $k_s$  denotes the permeability of the soil to be drained
- (c)  $O_{50}$  denotes the geotextile characteristic opening size
- (d)  $D_{50}$  denotes the soil particle size for which 50% are smaller
- (e)  $D_{85}$  denotes the soil particle size for which 85% are smaller
- (f) A denotes the safety factor applied for permeability (for normal applications, A = 1; for high clogging risk applications, A = 10)

## Mechanical design criteria

In addition the filter geotextile must also survive the installation process (relating to the mechanical criteria). If the geotextile does not have adequate mechanical properties, it may become punctured or torn during installation resulting in adverse effects on its hydraulic performance. The mechanical property requirements of the geotextile filter are related to the types and magnitudes of the stresses imparted by the permeable drainage media in contact with the geotextile filter. Most applications involve the filter geotextile to be in contact with stones. The installation for subsurface drainage applications typically involves either stones dropped directly onto the geotextile (eg. trench drains) or stones tipped onto a stabilised aggregate platform that is extended further by dozing the stones over the edge of the platform (eg. subsurface blanket drains). The installation for erosion control systems typically involves either stones dropped directly onto the geotextile (eg. revetments and scour protection layers) or the geotextile is placed after the stones have been installed (eg. reclamation dykes). When stones are dropped directly onto the geotextile, the mechanical strength requirement would depend on the size of stone and the height that it is dropped from. When stones are dozed from the edge of an aggregate platform, the mechanical strength requirement would depend on the size of stone and the subgrade CBR strength beneath the aggregate platform.

### Operating spectra of Mirafi® FW-Series geotextiles as filters for subsurface drainage applications

For a specific geotextile of known mechanical properties, it would be possible to develop an operating spectrum for subsurface drainage applications with a specific mode of installation of geotextile. Figure 1 shows the operating spectra of Mirafi® FW-Series geotextiles for use as filter layer at the underside of blanket drains. Figure 2 shows the operating spectra of Mirafi® FW-Series geotextiles for use as filter layer in trench drains.

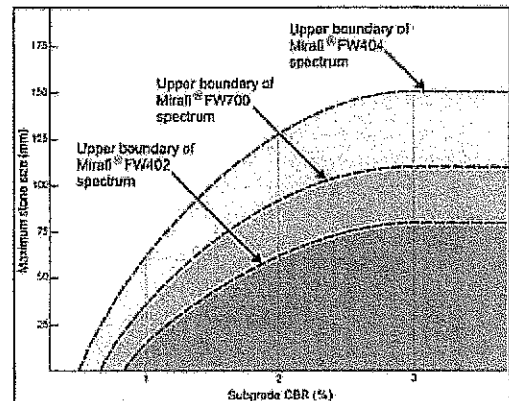

Figure 1: Operating spectra of Mirafi® FW-Series geotextiles for use at the underside of blanket drains

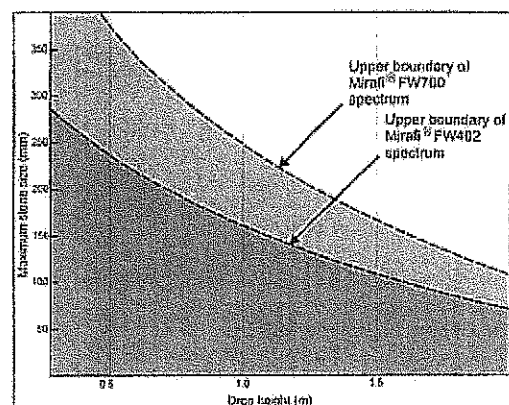

Figure 2: Operating spectra of Mirafi® FW-Series geotextiles for use in trench drains

# Filtration Design (2)

## Operating spectra of Mirafi® FW-Series geotextiles as filters for marine applications

For a specific geotextile of known mechanical properties, it would be possible to develop an operating spectrum for marine applications with a specific mode of installation of geotextile. Figure 3 shows the operating spectra of Mirafi® FW-Series geotextiles for use as filter layer in revetments and scour protection applications. Figure 4 shows the operating spectra of Mirafi® FW-Series geotextiles for use as filter layer between reclamation dykes and fill.

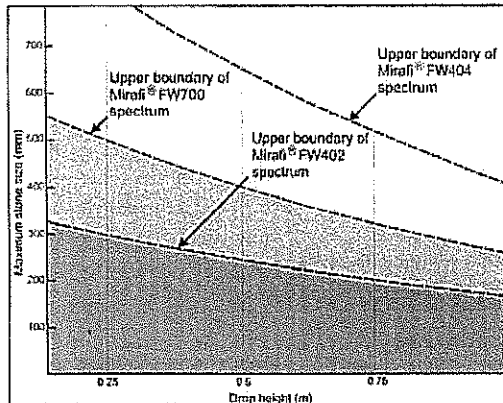

Figure 3: Operating spectra of Mirafi® FW-Series geotextiles for use in revetments and scour protection

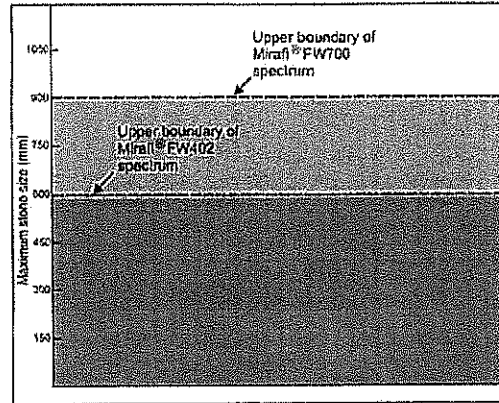

Figure 4: Operating spectra of Mirafi® FW-Series geotextiles for use between reclamation dykes and fill

## Leachate filtration in landfills

The role of geotextile filter in leachate drainage and collection system is to allow adequate leachate flow from the solid waste through to the drainage blanket and at the same time prevent or reduce clogging in the drainage gravel and pipes. The use of geotextile as a filter above the drainage gravel has been reported to result in less clogging than that observed in areas with no geotextile filter (Rowe et al., 2004).

Chemical and microbiological clogging is a critical issue for leachate filter geotextiles in landfills. The rate of reduction of geotextile permeability due to chemical and microbiological clogging is dependent on the initial pore size and the solid surface area that the leachate will come into contact with while flowing through the geotextile. Woven monofilament geotextiles (eg. Mirafi® FW-Series geotextiles) are the preferred engineering choice for leachate filtration. Giroud (1996) has discussed the issue of clogging as part of a broad review of filter design. He tentatively recommends that sand and nonwoven filters should not be used even if the waste has been stabilised to produce low strength leachate by pretreatment. Rather, he recommends the use of monofilament woven geotextiles. Percent opening area (POA) should be an additional specification item for leachate filter geotextiles. Koerner and Koerner (1995) recommended that for mild leachate, monofilament woven geotextiles should have a minimum POA of 10%. For more severe leachate conditions, the minimum POA of 15% should be specified as per the recommendation of Giroud (1996).

Leachate filter geotextiles are sometimes left uncovered for significant periods of time. UV resistance of geotextile is an important consideration and should also be a specification item for leachate filter geotextiles. It is recommended that a strength retention of 90% according to the UV resistance test ASTM D4355 be specified.

Filtration is a critical element in design and geotextile filters must not be selected on cost alone. Often, the cost of geotextile filters is an insignificant contribution to the overall project cost but the consequence of problems associated with use of an inadequate geotextile filter can be very significant.

## References

Giroud, J.P. (1996). *Granular Filters and Geotextile Filters*, Proceedings Geofilters '96, pp. 565-680.

Koerner, R.M. & Koerner, G.R. (1995). *Leachate clogging assessment of geotextile (and soil) landfill for filters*, US EPA Report, CR-819371, March.

Rowe, R.K., Quigley, R.M. & Booker, J.R. (2004). *Barrier Systems for Waste Disposal Facilities*, 2<sup>nd</sup> Edition, Spon Press: London & New York, 978 pgs.

**9.6 Appendix F**  
**- Technical Properties of the**  
**Steel Mesh Material – Golik 228G**



# GALVANIZED / STAINLESS STEEL MESH 鍍鋅 / 不銹鋼網

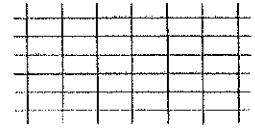

Golik Reference No. 高力編號		Diameter 鍍鋅線規格		Pitch 網眼規格		Sheet Size 網片規格		Weight 重量
Galvanized Steel 鍍鋅	Stainless Steel 不銹鋼	Main 直 (mm)	Cross 橫 (mm)	Main 直 (A) (mm)	Cross 橫 (B) (mm)	Width 闊 (W) (Metre)	Length 長 (L) (Metre)	
21G	21S	4.00	3.00	50	25	2.1	x 3.6	4.18
210G	210S	3.00	3.00	50	50	2.1	x 3.6	2.20
228G	228S	4.00	4.00	50	50	2.1	x 3.6	3.96
31G	31S	4.00	3.00	75	25	2.1	x 3.6	3.52
310G	310S	3.00	3.00	75	75	2.1	x 3.6	1.46
3110G	3110S	3.00	3.00	75	25	2.1	x 3.6	2.93
310aG	-	3.20	3.20	75	75	2.1	x 3.6	1.68
410G	410S	3.00	3.00	100	100	2.1	x 3.6	1.11
48G	48S	4.00	4.00	100	100	2.1	x 3.6	1.98
1111G	1111S	3.00	3.00	25	25	2.1	x 3.6	4.40
1112G	1112S	2.70	2.70	25	25	1.2	x 2.1	3.64
3315 *	- *	1.50	1.50	75	75	1.8	x 30.0	0.36
D31 *	D31S *	2.00	2.00	100	100	1.8	x 60.0	0.50
E31 *	E31S *	2.00	2.00	50	50	1.8	x 30.0	0.99
D49 *	D49S *	2.50	2.50	100	100	1.8	x 50.0	0.77
E49 *	E49S *	2.50	2.50	50	50	1.8	x 20.0	1.54
E49a (2212) *	E49aS *	2.70	2.70	50	50	1.8	x 20.0	1.80
1520G *	1520S *	1.50	1.50	20	20	0.915	x 30.0	1.40
1117G *	1117S *	1.50	1.50	25	25	0.915	x 30.0	1.12
1118G *	1118S *	1.20	1.20	25	25	0.915	x 30.0	0.72
1119G *	1119S *	1.00	1.00	25	25	0.915	x 30.0	0.48

Remark : (1) "\*" Types of mesh are supplied in form of rolls.  
 (2) Stainless Steel Mesh is supplied in grade of AISI 304 and AISI 316.

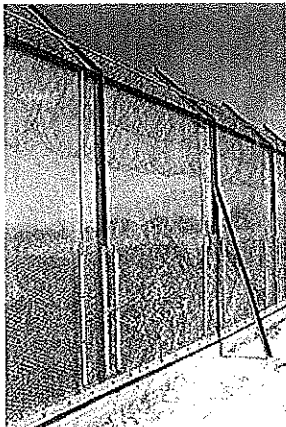
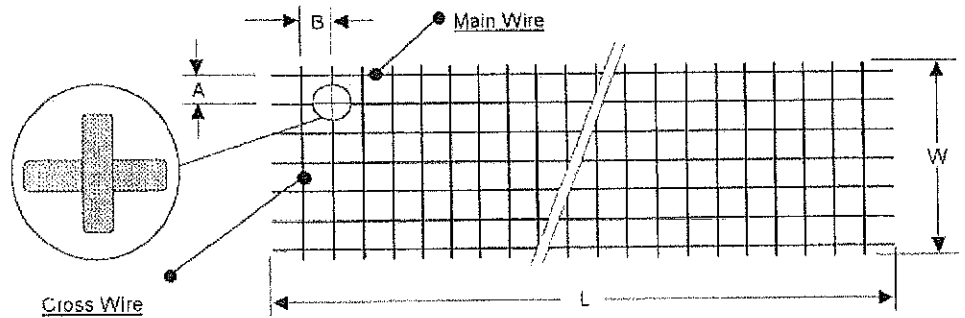

Galvanized Mesh used in Fencing  
 使用於圍欄之鍍鋅網

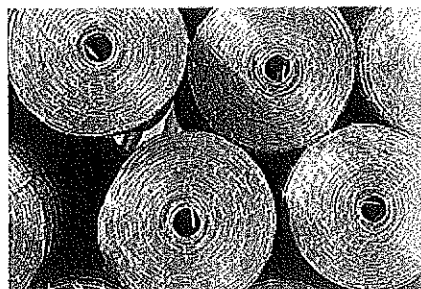

Galvanized Mesh in rolls  
 卷裝鍍鋅網

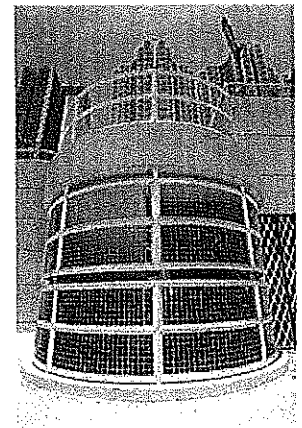

Other usage of Galvanized Mesh  
 鍍鋅網之其它使用方法



## INTRODUCTION 公司簡介

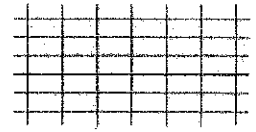

Golik Metal Manufacturing Co., Ltd. was established in 1977 and rapidly emerged as one of Hong Kong's leading manufacturers and suppliers of Welded Steel Wire Fabric and steel mesh related products used in the building and civil construction works.

Our experience has been acquired over 25 years of manufacturing Welded Steel Wire Fabric. During the Period, we have produced over 250,000 tons of Fabric and related products destined for most projects in Hong Kong, Macau and China.

Golik had successfully acquired the qualification of ISO 9002 Certification in 1995 and ISO 9001: 2000 in 2003. In addition, Golik had been approved as Quality Assured Stockist in 1998, for reinforcing steel bars.

This brochure is intended to provide product information, material specifications and some technical details of Welded Steel Wire Fabric for Architects, Designers, Engineers, and Contractors.

高力金屬製品廠有限公司創立於1977年。現已發展成為香港主要的熔接鋼筋網生產商及其它有關之鋼網產品供應商。

我們已有超過 25 年生產及供應熔接鋼筋網的經驗。其間已生產超過 250,000 噸各種熔接鋼筋網供應香港、澳門及中國地區的各頂大小房屋及基建工程。

高力於一九九五年成功獲取 ISO 9002 之國際認證，並於二零零三年提升為 ISO 9001: 2000 年版本之審核驗證；在一九九八年則通過 Quality Assured Stockist 認證，成為認可之熱軋鋼筋供應商。

這產品目錄主要是提供所生產鋼筋網之標準及規格，以及一些使用的技術資料，以加深各有關之技術人員（則師、設計人員、工程師）及承建商對熔接鋼筋網之了解。



## OUR PRODUCTS 產品介紹

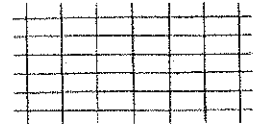

### BENEFITS OF USING GOLIK FABRIC

#### 高力鋼筋網的優點

In an environment of increased site-labour cost, Golik Fabric provides Developers, Designers, Engineers and Contractors a convenient and economical steel reinforcement for concrete structures. Golik produces wide range of mesh products include Standard Fabric, Non-standard Fabric and tailor-made Engineered Fabric. Other products such as galvanized finemesh, galvanized wire mesh and hard-drawn wires etc.

在目前建築業勞工成本上升情況下，高力鋼筋網給發展商、設計師、工程師及建築商提供了一種使用於混凝土結構上之經濟、方便及高效能的建築材料。我們的產品包括標準、非標準及特定規格鋼筋網，其他產品包括有鍍鋅電焊網及冷拉鋼筋等。

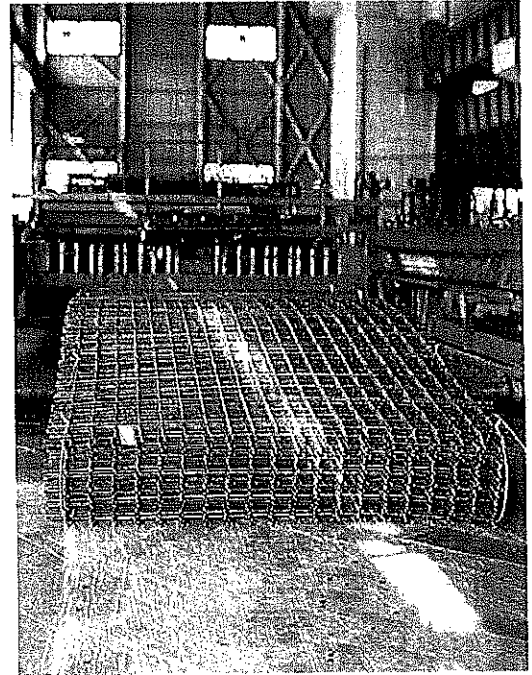

### GOLIK FABRIC FOR CONCRETE REINFORCEMENT

#### 高力鋼筋網用於混凝土結構

Golik Fabric is a prefabricated steel product which replaces traditional steel cutting and fixing. The higher strength of the Golik Fabric can considerably save the quantity of steel used on a project.

高力鋼筋網主要是用以代替傳統人手裁剪及固定鋼筋的建築方法。使用高強度性能的高力鋼筋網代替傳統方法可以節省鋼材。

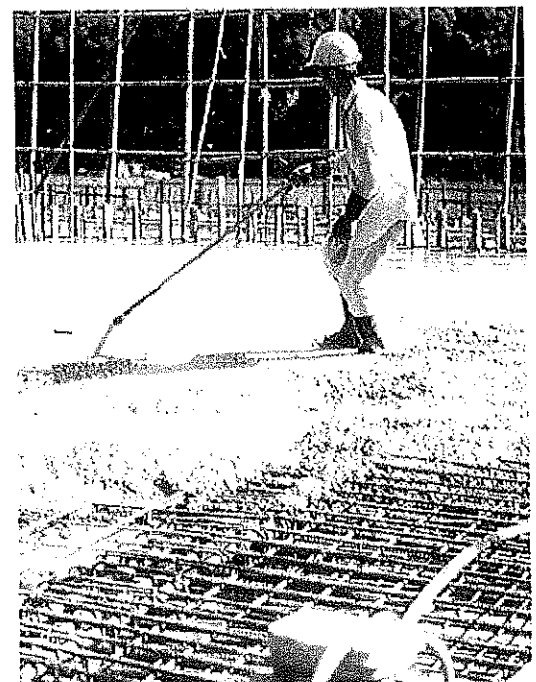



## APPLICATIONS 用途

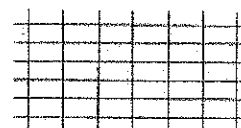

### GOLIK FABRIC IS QUALITY STEEL FIXING

#### 高力鋼筋網能保證工程質量

The spacing of the steel wires is uniformly controlled, as Golik Fabric is produced by fully computerized mesh making machines. Each wire intersection is welded with a controlled weld, not loosely fixed with tying wire. Golik Fabric eliminates human error in manual steel fixing. Golik Fabric is widely used for the following applications: **Paving, Buildings, Concrete Pipes, Shaped Fabric, Precast Components etc.**

高力鋼筋網的鋼筋排放是標準化及機械化。使用標準化的鋼筋網可以大大減少由人手綁扎而做成的錯漏。高力鋼筋網片已廣泛地被使用於：路面地台、高層建築物、水泥管、混凝土預製件等。

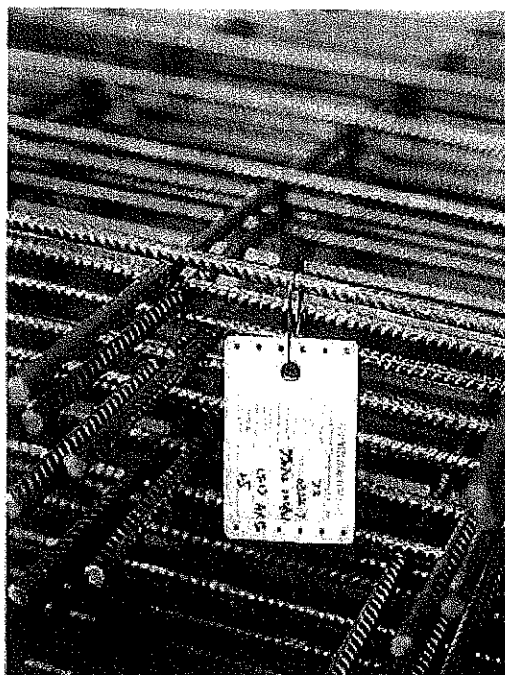

### PAVING

#### 路面及地台

Concrete pavements are exposed directly to atmospheric conditions, expanding and contracting with every change of temperature or moisture condition. Golik Fabric functions as shrinkage reinforcement, permitting the transfer of internal stresses and loads, maintaining an even surface, and safeguarding the strength and durability of the pavement.

一般混凝土路面龜裂的主要原因是受到溫度及濕度變化而膨脹或收縮。高力鋼筋能有效地加強路面之強度及平均分散路面所承受之壓力，有效地減少混凝土路面出現龜裂之情況。





## APPLICATIONS 用途

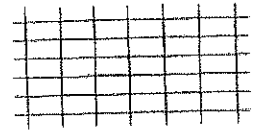

### BUILDINGS

#### 高層建築物

Golik Fabric is used successfully and economically in practically every form of concrete building such as footings, slabs, walls, staircases, refuse chutes. Golik Fabric is adaptable for use for all types of building designs, including public housing, office buildings, schools, hospitals, industrial and commercial buildings, airport hardstanding's, apartments and other residential buildings.

高力鋼筋網在高層建築工程中代替普通鋼筋都有非常成功及滿意的效果。工程包括有公共房屋、政府辦公大樓、學校、醫院、工業及商業大廈等。從數據顯示，使用高力鋼筋網能夠節省大量人手及施工時間。

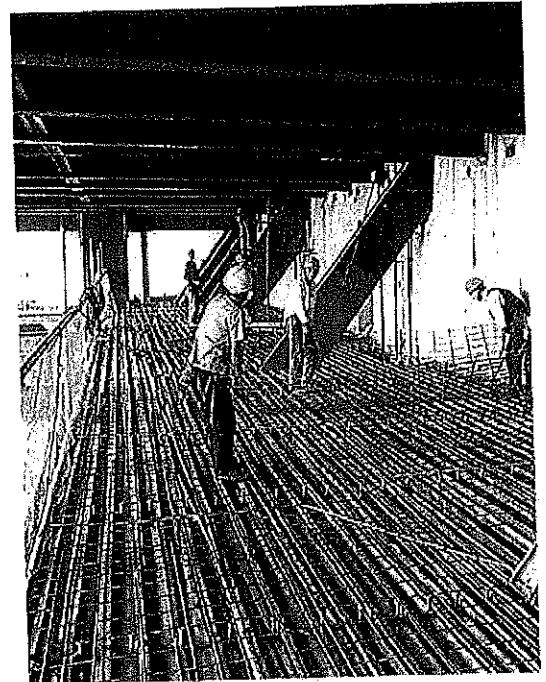

### CONCRETE PIPES

#### 預製水泥管

Golik Fabric and Golik Hard Drawn Wire are standard reinforcing materials used in the manufacture of concrete pipes. Welded steel fabric is used because of its high strength and consequently, less material is required. If mild steel bars are used in the same application, about 40% more steel is required.

高力鋼筋網及冷拉鋼筋用於生產預製大型水泥管是一種堅固及標準化之材料。由於熔接鋼筋網的抗拉强度高，在製造同一產品時，比使用普通鋼筋節省高達 40% 之材料。

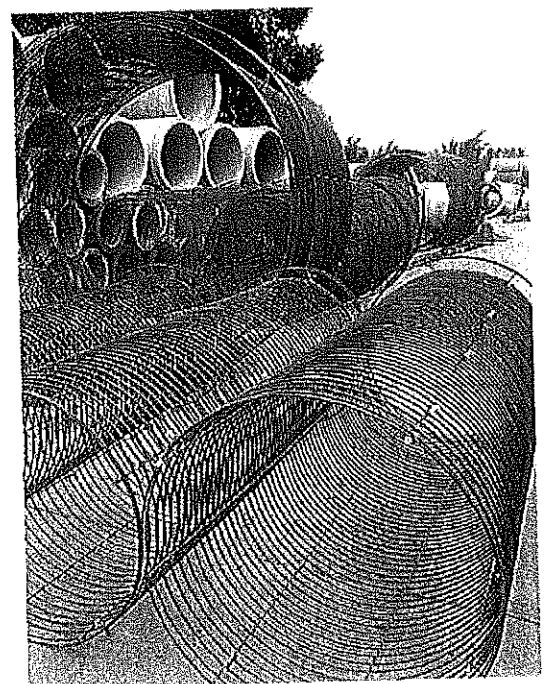





## APPLICATIONS 用途

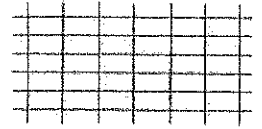

### SHAPED FABRIC

#### 成型鋼筋網

Golik Fabric can easily be bent to required shapes, U-shape or L-shape or trapezoidal to reinforce concrete walls, panels, floor slabs or drains. Use of shaped fabric ensures better quality workmanship, lower steel wastage and higher productivity.

高力鋼筋網可以加工屈成各種形狀如 U 型、L 型或其他特別形狀；以配合設計不同之結構混凝土牆、預製牆、樓面及水渠等。使用已加工成形之鋼筋網可以保證工程質量，減低鋼材損耗及能提高效率。

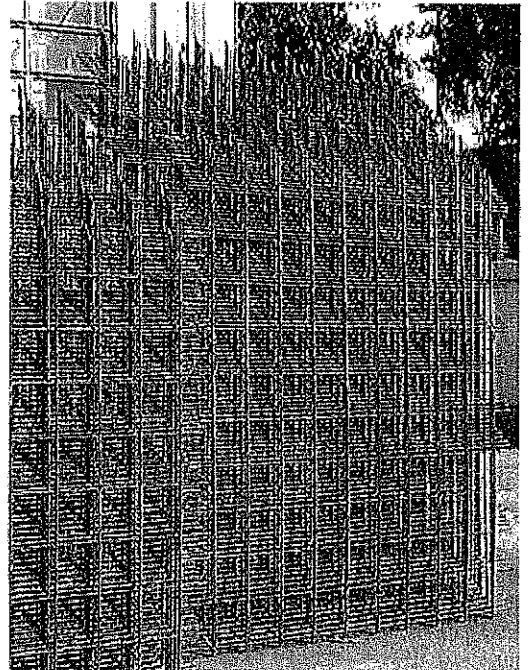

### PRECAST COMPONENTS

#### 預製混凝土產品

The quality of construction work has improved significantly with the use of precast components. Golik Fabric is widely used in precast components ranging from architectural precast facades, parapet walls, lightweight partition panels, sun shades, staircases, refuse chutes, planks ( slabs ), water tanks, secondary roofing, U-drains and box culverts etc.

在建築工程中使用預製混凝土件可以把工程質量大大提高。高力熔接鋼筋網是預製混凝土產品最好的結構材料；已被廣泛地使用於大部份鋼筋混凝土件如樓宇外牆、間格牆、簷蓬、樓梯及樓面板等。

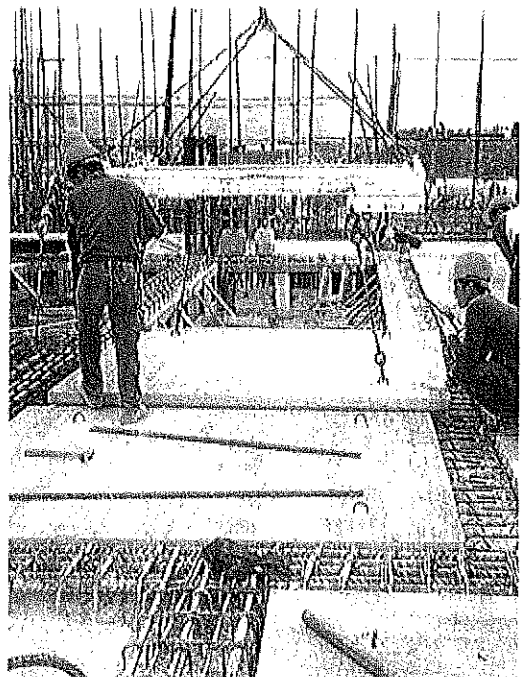



## SPECIFICATIONS 標準

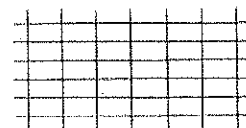

### CONFORMITY TO INTERNATIONAL STANDARDS

#### 符合國際標準

Golik Fabric is manufactured in accordance with the following standards :

- BS4482 "Cold Reduced Steel Wire for the Reinforcement of Concrete"
- BS4483 "Steel Fabric for the Reinforcement of Concrete"
- BS4466 "Scheduling, dimensioning, bending and cutting of steel reinforcement for concrete"
- ASTM A82 "Steel Wire, Plain, for Concrete Reinforcement"
- ASTM A185 "Steel Welded Wire Fabric, Plain, for Concrete Reinforcement"

高力鋼筋網是按照以下標準生產：

- 英國標準 BS4482:1985
- 英國標準 BS4483:1985
- 英國標準 BS4466:1989
- 美國標準 ASTM A82
- 美國標準 ASTM A185

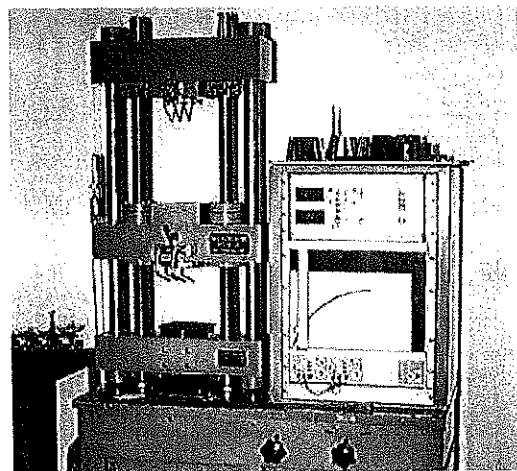

### TENSILE PROPERTIES

#### 拉伸特性

The British Standards BS4482:1985 & BS4483:1985, requires that the cold-drawn steel wire used in the Welded Steel Fabric must have a minimum proof stress of  $460\text{N/mm}^2$ .

英國標準 BS4482:1985 及 BS4483:1985 要求用作生產熔焊鋼筋網的“冷拉鋼筋”之屈服強度不少於  $460\text{N/mm}^2$ 。

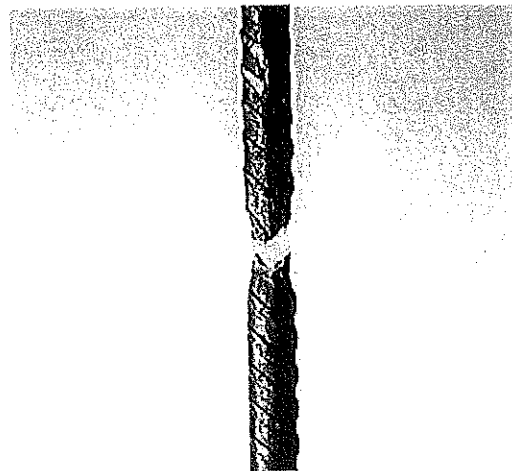

### WELD SHEAR

#### 熔接點強度

Golik Fabric is welded into secure mats of reinforcement. The shearing load required to produce failure of a welded intersection is not less than  $0.25 A f_y$  where A is the nominal cross-sectional area of the smaller wire and  $f_y = 460\text{N/mm}^2$ .

高力鋼筋網是利用電焊方法將縱橫鋼筋熔接。熔接點的剪斷強度要求不低於  $0.25 A f_y$ ，A 是較小的鋼筋之橫切面積， $f_y$  是等於  $460\text{N/mm}^2$ 。

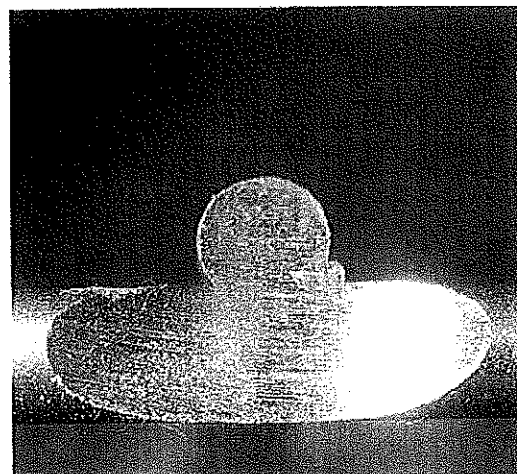



## SPECIFICATIONS 標準

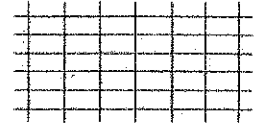

### GOLIK FABRIC

#### 高力鋼筋網

Golik Fabric is prefabricated steel reinforcement consisting of a series of parallel, longitudinal, cold-drawn high-yield steel wires welded at regular intervals to transverse wires. Golik Fabric is manufactured on automatic welding machines, ensuring uniform spacing of wires providing consistent cross sectional areas of steel.

高力鋼筋網是使用經過冷拉處理而成之高抗拉力鋼筋，進行有規則之縱橫方向排列後焊接而製成的。

高力鋼筋網是使用大型自動焊接機，按照標準大批量焊製成鋼筋網片；使用電腦控制之焊接機能保證生產出質量及規格統一之鋼筋網片。

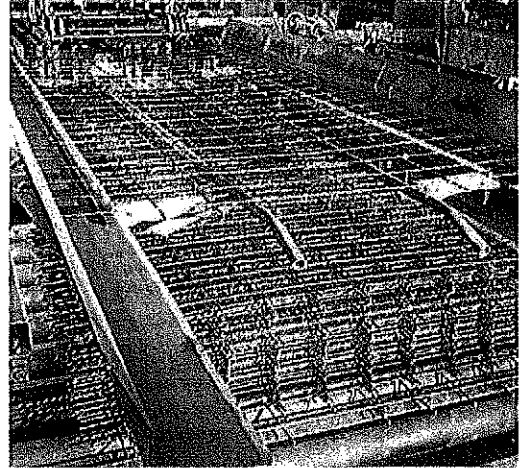

### PLAIN ROUND STEEL FABRIC

#### 光面鋼筋網

Plain round Steel Fabric has been used as prefabricated reinforcement for reinforced concrete construction around the world for more than sixty years.

光面鋼筋網片使用於鋼筋混凝土在世界各地建築工程方面已有超過60年歷史。

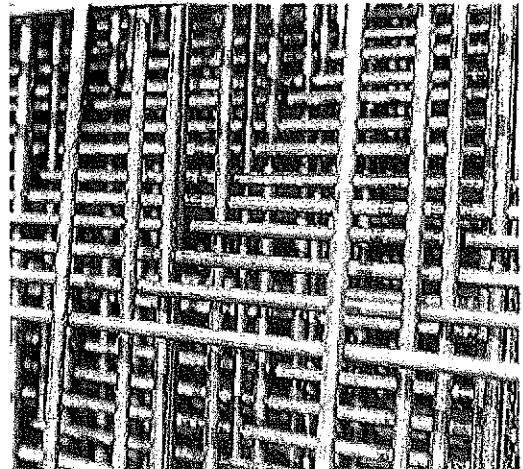

### DEFORMED STEEL WIRE

#### 帶肋鋼筋

Deformed Steel Wire is used as reinforcement for various concrete elements and structures either as wire, cut into lengths, or bent into the required shape to fix into the concrete. Deformed Wire complies to all the requirements BS4482, BS4466 and BS4449 weldable quality steel reinforcement. The deformations improve the "local bond" of the steel bars in the concrete.

帶肋鋼筋已廣泛地用於鋼筋混凝土方面，可以剪切成長短及屈成不同形狀。帶肋鋼筋符合 BS4482, BS4466 及 BS4449 標準，帶肋鋼筋可以增強鋼筋在混凝土中的"附著力"。

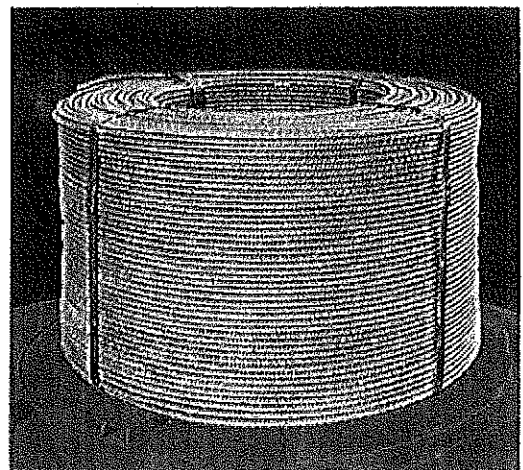



# APPLICATIONS OF FABRIC 鋼筋網應用

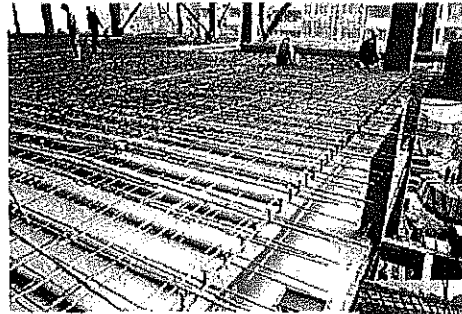
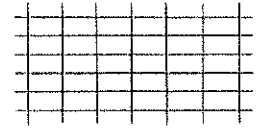

Floor Making of Buildings  
多層大廈之樓面鋪設

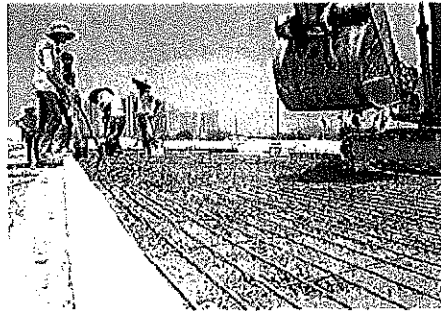

Paving of Motor way  
鋪設行車公路

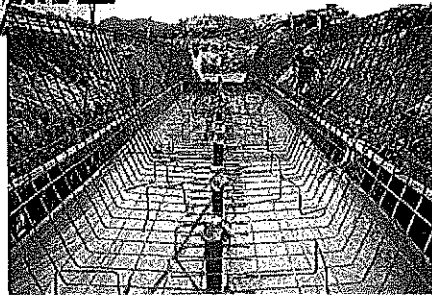

Channel of Drainage  
河道骨架

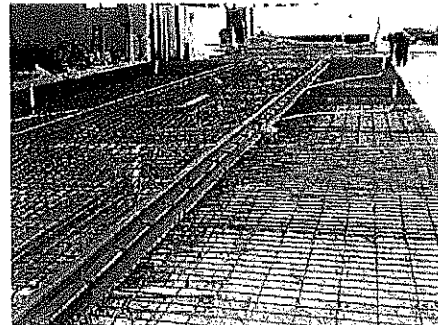

Concrete Pavement  
混凝土地台

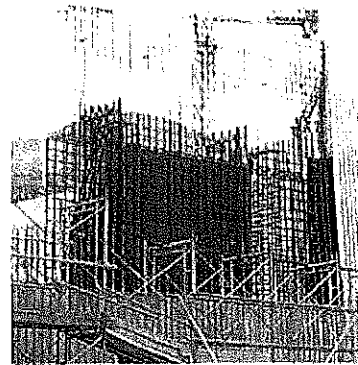

Protecting Wall Constructing  
保護牆之建造

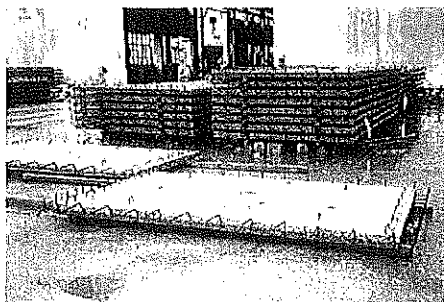

Semi-Precast Slabs  
預製樓面板

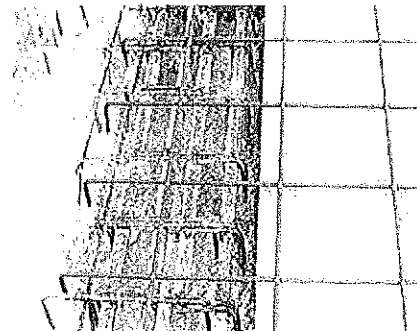

Wall and Slab intersection  
牆身與樓面接合



PROJECT REFERENCES 參予工程

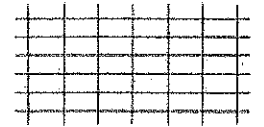

Hong Kong International Airport  
香港國際機場



Central Plaza  
中環廣場

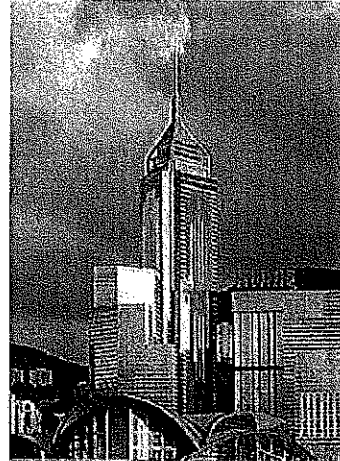

Western Cross Harbour Tunnel  
西隧

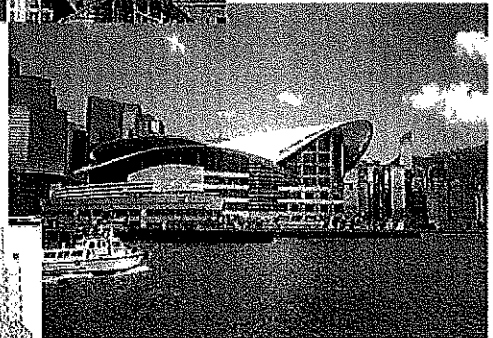

Hong Kong Convention & Exhibition Centre  
香港會議展覽中心

Times Square  
時代廣場

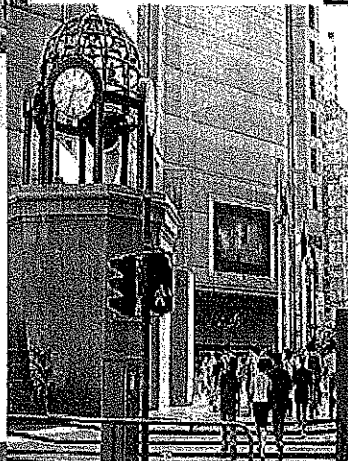

Tsing Ma Bridge  
青馬大橋

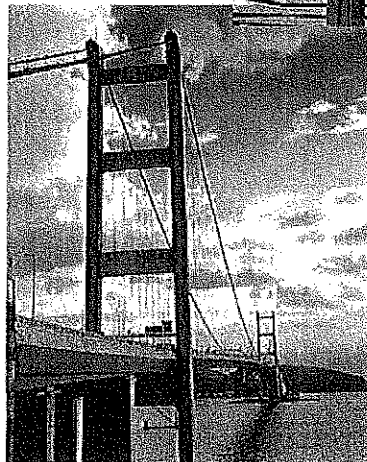

The Hong Kong and Shanghai Banking Corporation Headquarter  
香港滙豐銀行總行



PROJECT REFERENCES 參予工程

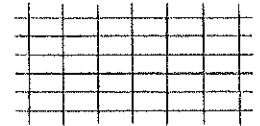

Tai Po Water Treatment and Pumping Work  
大埔抽水站工程

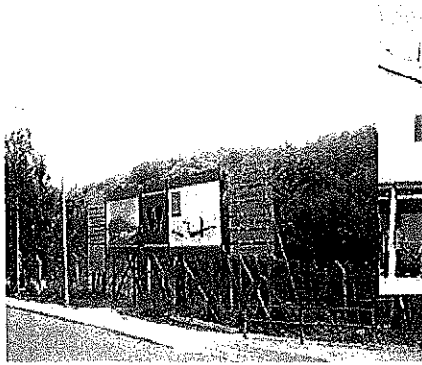

MTR Tseung Kwan O Station  
地鐵將軍澳站

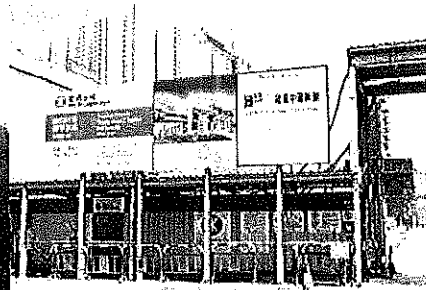

Tseung Kwan O MTR Depot  
將軍澳地鐵車廠

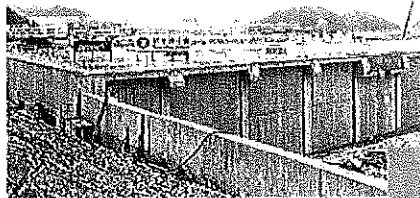

Yau Tong No.2 Reservoir  
油塘二號水庫

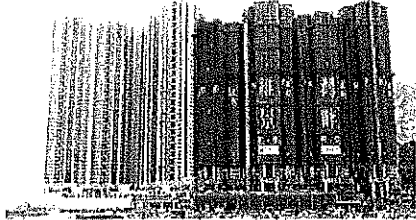
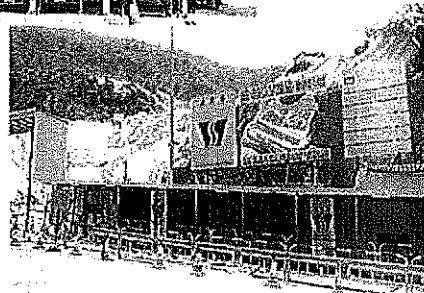

Ocean Shore Phase I & II  
匯景灣第一及二期



Tseung Kwan O Bauhinia Garden  
將軍澳寶盈花園

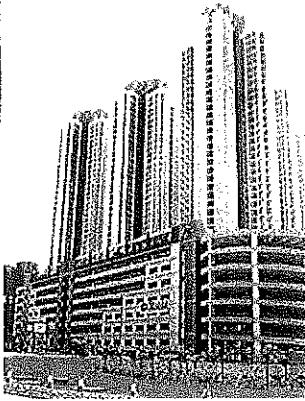

Tseung Kwan O Choi Ming Court  
將軍澳彩明苑

North District Hospital  
北區醫院

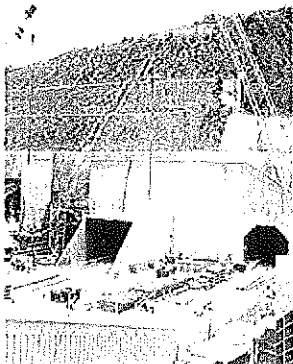
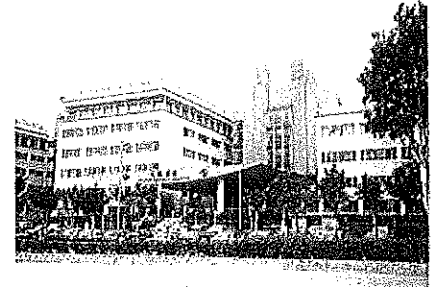

Tseung Kwan O Pak Shing Kwok Tunnels  
將軍澳白鵝角隧道

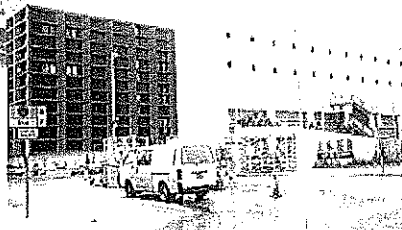

Sheung Shui Slaughterhouse  
上水屠房

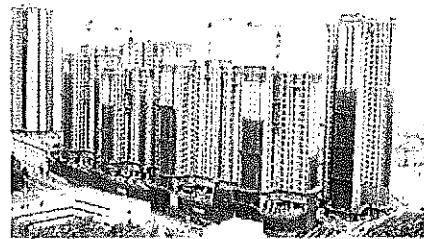

Yau Tong Phase 5  
油塘 6 期



# QUALITY ASSURANCE 質量保證

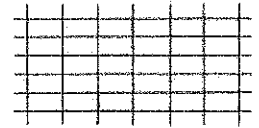

**SGS** SGS United Kingdom Ltd  
Yasley International Certification Services

## ASSESSMENT SCHEDULE

Q5187

**Assessment Standard:** ISO 9001 : 2000

**Company:** Golik Metal Industrial Co., Ltd.  
Golik Metal Manufacturing Co., Ltd.  
Golik Steel Co., Ltd.

**Location:** Suite 5608, Central Plaza, 18 Harbour Road  
Wanchai, Hong Kong

3 Dai Shing Street, Tai Po Industrial Estate  
Tai Po, N. T., Hong Kong

DD132, Tong Hang Road, Lot 775-777  
Tuen Mun, N. T., Hong Kong

**Product Area Assessed:** Supply, stockholding and manufacture of steel  
wire fabrics to BS4482, BS4483 and BS 4486  
Supply and stockholding of reinforcing bars to  
BS 4449 and BS 4449 Class 2

Authorised by  
  
Director

Issue No: 7  
06 March 2003  
Page 1 of 1

Further clarifications regarding the scope of this certificate and the applicability of ISO 9001:2000 requirements may be obtained by consulting the signatories.

SGS Yasley International Certification Services is accredited by the  
following authorities:  
UK - United Kingdom Accreditation Service (UKAS)



**SGS** SGS United Kingdom Ltd  
Yasley International Certification Services

Certificate Number

Q5187

This is to certify that the  
Quality Management systems of

Golik Metal Industrial Co., Ltd.  
Golik Metal Manufacturing  
Co., Ltd.  
Golik Steel Co., Ltd.  
Hong Kong

have been assessed and registered as meeting the  
requirements of ISO 9001

The scope of registration is detailed on the Assessment  
Schedule bearing this certificate number.

SGS Yasley International Certification Services  
Signed by

06 June 2003 06 March 2003

For the signatory, Certification and  
The certificate will be subject to surveillance  
visits on the appropriate schedule for the  
certificate duration.



SGS Yasley International Certification Services  
is a member of SGS Group (Singapore) Pte  
Ltd. Registered Company (41828)  
Registered Office  
505 North Bridge Road, Singapore  
Singapore 049213



For a full list of products and services for which  
this certificate is valid, please refer to the  
scope of registration on the assessment schedule.  
This certificate is subject to periodic surveillance  
visits on the appropriate schedule for the  
certificate duration.

Member of the SGS Group, Singapore Office of Yasley  
SGS (S) PTE LTD

**SGS** SGS Hong Kong Limited  
International Certification Services

Certificate Number

Q0040.HK.HK

This is to certify that the  
Quality Management systems of

Golik Metal Industrial Co., Ltd.  
Golik Metal Manufacturing  
Co., Ltd.  
Golik Steel Co., Ltd.  
Hong Kong

have been assessed and registered as meeting the  
requirements of ISO 9001

The scope of registration is detailed on the Assessment  
Schedule bearing this certificate number.

SGS Hong Kong Limited  
International Certification Services  
Signed by

16 March 2003 06 March 2003  
For the signatory, Certification and  
This certificate will be subject to  
surveillance visits on the appropriate



Registered Office  
SGS Hong Kong Limited  
International Certification Services  
19, Des Voeux Road, Central  
11, Lee Yee Street, NT, Hong Kong



Member of the SGS Group, Singapore Office of Yasley  
SGS (S) PTE LTD

**SGS** SGS Hong Kong Limited  
International Certification Services

## ASSESSMENT SCHEDULE

Q0040.HK.HK

**Assessment Standard:** ISO 9001 : 2000

**Company:** Golik Metal Industrial Co., Ltd.  
Golik Metal Manufacturing Co., Ltd.  
Golik Steel Co., Ltd.

**Locations:** Suite 5608, Central Plaza, 18 Harbour Road  
Wanchai, Hong Kong

3 Dai Shing Street, Tai Po Industrial Estate  
Tai Po, N. T., Hong Kong

DD132, Tong Hang Road, Lot 775-777  
Tuen Mun, N. T., Hong Kong

**Product Area Assessed:** Supply, stockholding and manufacture of steel  
wire fabrics to BS4482, BS4483 and BS 4486  
Supply and stockholding of reinforcing bars to  
BS 4449 and BS 4449 Class 2

Authorised by

16 March 2003

Page 1 of 1

Further clarifications regarding the scope of this certificate and the applicability of ISO 9001:2000 requirements may be obtained by consulting the signatories.

Member of the SGS Group, Singapore Office of Yasley  
SGS (S) PTE LTD



**9.7 Appendix G**  
**- Access of Environmental Team**  
**to carry out water measurement**  
**and sampling**



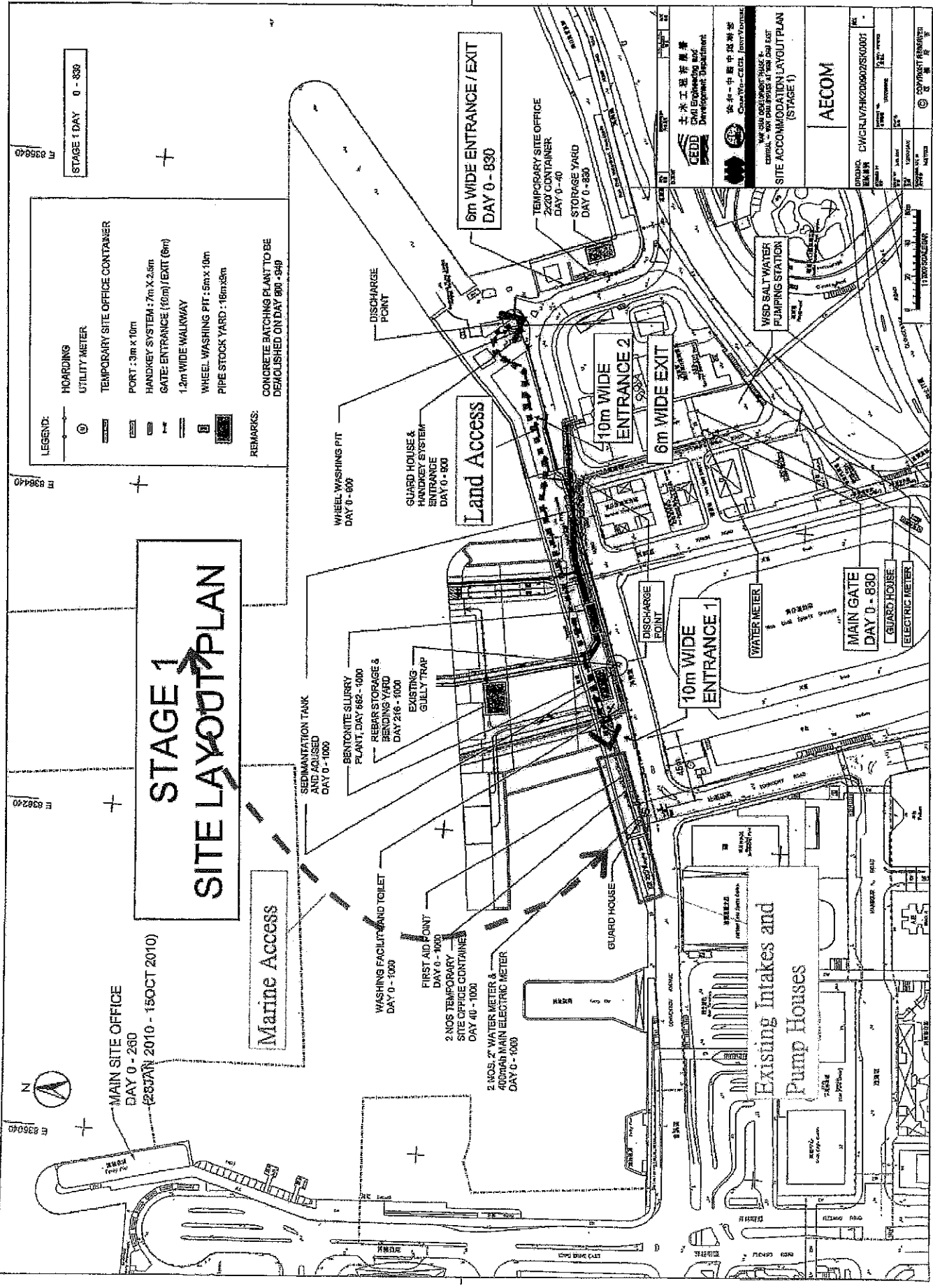

STAGE 1 DAY 0 - 830

- LEGEND:**
- HOARDING
  - UTILITY METER
  - TEMPORARY SITE OFFICE CONTAINER
  - PORT : 3m x 10m
  - HANDKEY SYSTEM : 7m X 2.5m
  - GATE- ENTRANCE (10m) /EXIT (6m)
  - 1.2m WIDE WALKWAY
  - WHEEL WASHING PIT : 5m x 10m
  - PIPE STOCK YARD : 16m x 8m
- REMARKS:**
- CONCRETE BATCHING PLANT TO BE DEMOLISHED ON DAY 800 - 849

# STAGE 1 SITE LAYOUT PLAN

MAIN SITE OFFICE  
DAY 0 - 280  
(28 JAN 2010 - 15 OCT 2010)

Marine Access

SEDIMENTATION TANK  
AND ROUSED  
DAY 0 - 1000

BENTONITE SLURRY  
PLANT, DAY 662 - 1000

REBAR STORAGE &  
BENDING YARD  
DAY 216 - 1000

WASHING FACILITY AND TOILET  
DAY 0 - 1000

FIRST AID POINT  
DAY 0 - 1000

2 NOS TEMPORARY  
SITE OFFICE CONTAINERS  
DAY 40 - 1000

2 NOS. 2" WATER METER &  
4000MM MAIN ELECTRIC METER  
DAY 0 - 1000

WHEEL WASHING PIT  
DAY 0 - 800

GUARD HOUSE &  
HANDKEY SYSTEM  
ENTRANCE  
DAY 0 - 800

Land Access

6m WIDE ENTRANCE /EXIT  
DAY 0 - 830

TEMPORARY SITE OFFICE  
2400 CONTAINER  
DAY 0 - 40

STORAGE YARD  
DAY 0 - 830

10m WIDE  
ENTRANCE 2

6m WIDE EXIT

10m WIDE  
ENTRANCE 1

DISCHARGE POINT

WATER METER

MAIN GATE  
DAY 0 - 830

GUARD HOUSE

ELECTRIC METER

Existing Intakes and  
Pump Houses

USED SALT WATER  
PUMPING STATION

AECOM

PROJECT NO.	CW/CRLV/HK2000/02/SK0001
DATE	11/03/2009
SCALE	AS SHOWN
DESIGNER	CHEN YU
CHECKER	CHEN YU
APPROVER	CHEN YU
DATE	11/03/2009
PROJECT	CONTRACT PHASE 1

CECO  
土木工程有限公司  
Civil Engineering and  
Development Department

中環 - 中國中環辦事處  
Coco-We-COLO, Coco-We-COLO

WE CAN DO ANYTHING!  
CONTRACT - WE CAN PROVIDE IT FOR YOU!

SITE ACCOMMODATION LAYOUT PLAN  
(STAGE 1)





# Lam Geotechnics Limited

Ground Investigation & Instrumentation Professionals

華益土力有限公司

Ref : G1001/CS/L069/FEP-03/356/2009  
Date : 20 April 2010

## Chun Wo – CRGL Joint Venture

5C, Hong Kong Spinners Industrial Building, Phase I,  
602 – 603 Tai Nan Street,  
Cheung Sha Wan  
Kowloon

### Attn: Project Manager

Dear Sir,

### **Contract No. HK/2009/05**

**Wanchai Development Phase II and Central-Wanchai Bypass  
Silt Screen Deployment Plan (Revision A) under FEP-03/356/2009**

Referring to the Chun Wo – CRGL Joint Venture submission dated 12 April 2010 we have reviewed your submitted details and hereby certified this submission in accordance with Condition 2.9 of FEP-03/356/2009.

Should you have any enquiry, please feel free to contact the undersigned at 2839 5666.

Yours faithfully,

Raymond Dai  
Environmental Team Leader

c.c.

CEDD	- Mr. Patrick Keung	(By Email)
AECOM	- Mr. David Kwan	(By Email)
ENVIRON	- Mr. David Yeung	(By Email)

Ref.: AACWBIECEM00\_0\_0137L.10

21 April 2010

Chun Wo – CRGL Joint Venture  
5C, Hong Kong Spinners Industrial Building Phase 1  
601-603 Tai Nan West Street  
Cheung Sha Wan  
Kowloon

By Post and E-mail

Attention: Mr. Cecil Cheng

Dear Sir,

**Re: FEP-03/356/2009**  
**Contract No. HK/2009/02**  
**Wan Chai Development Phase II – Central-Wan Chai Bypass at Wan Chai East**  
**Silt Screen Deployment Plan (Rev. A)**

Reference is made to Chun Wo – CRGL Joint Venture's submission of Silt Screen Deployment Plan (Rev. A) dated 12 April 2010 for our review and comment.

Please be informed that we have no adverse comments on the captioned submission. We also write to verify the captioned submission in accordance with Condition 2.9 of FEP-03/356/2009.

Thank you for your kind attention.

Yours sincerely,

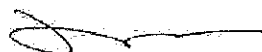

David Yeung  
Independent Environmental Checker

c.c.	CEDD	Mr. Patrick Keung	by email
	AECOM	Mr. David Kwan	by email
	LAM	Mr. Raymond Dai	by email

Q:\Projects\AACWBIECEM00\Corr\AACWBIECEM00\_0\_0137L.10.doc

